

# Georgia Milestones

Assessment System



## Study/Resource Guide for Students and Parents Grade 8



The Study/Resource Guides are intended to serve as a resource for parents and students. They contain practice questions and learning activities for each content area. The standards identified in the Study/Resource Guides address a sampling of the state-mandated content standards.

For the purposes of day-to-day classroom instruction, teachers should consult the wide array of resources that can be found at [www.georgiastandards.org](http://www.georgiastandards.org).

**Study/Resource Guide**

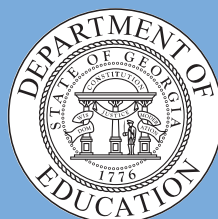

# Table of Contents

<b>THE GEORGIA MILESTONES ASSESSMENT SYSTEM</b>	<b>3</b>
<b>HOW TO USE THIS GUIDE</b>	<b>4</b>
<b>PREPARING FOR TAKING TESTS</b>	<b>5</b>
<b>OVERVIEW OF THE END-OF-GRADE ASSESSMENT</b>	<b>6</b>
TYPES OF ITEMS	6
<b>DEPTH OF KNOWLEDGE</b>	<b>7</b>
<b>ENGLISH LANGUAGE ARTS (ELA)</b>	<b>10</b>
DESCRIPTION OF TEST FORMAT AND ORGANIZATION	10
CONTENT	10
ITEM TYPES	10
ENGLISH LANGUAGE ARTS (ELA) DEPTH OF KNOWLEDGE EXAMPLE ITEMS	11
ENGLISH LANGUAGE ARTS (ELA) CONTENT DESCRIPTION AND ADDITIONAL SAMPLE ITEMS	21
ENGLISH LANGUAGE ARTS (ELA) ADDITIONAL SAMPLE ITEM KEYS	54
ENGLISH LANGUAGE ARTS (ELA) SAMPLE SCORING RUBRICS AND EXEMPLAR RESPONSES	57
ENGLISH LANGUAGE ARTS (ELA) WRITING RUBRICS	63
<b>MATHEMATICS</b>	<b>72</b>
DESCRIPTION OF TEST FORMAT AND ORGANIZATION	72
CONTENT	72
ITEM TYPES	72
MATHEMATICS DEPTH OF KNOWLEDGE EXAMPLE ITEMS	73
MATHEMATICS CONTENT DESCRIPTION AND ADDITIONAL SAMPLE ITEMS	81
MATHEMATICS ADDITIONAL SAMPLE ITEM KEYS	110
MATHEMATICS SAMPLE SCORING RUBRICS AND EXEMPLAR RESPONSES	113
<b>SCIENCE</b>	<b>126</b>
DESCRIPTION OF TEST FORMAT AND ORGANIZATION	126
CONTENT	126
ITEM TYPES	126
SCIENCE DEPTH OF KNOWLEDGE EXAMPLE ITEMS	127
SCIENCE CONTENT DESCRIPTION AND ADDITIONAL SAMPLE ITEMS	131
SCIENCE ADDITIONAL SAMPLE ITEM KEYS	159
<b>SOCIAL STUDIES</b>	<b>173</b>
DESCRIPTION OF TEST FORMAT AND ORGANIZATION	173
CONTENT	173
ITEM TYPES	173
SOCIAL STUDIES DEPTH OF KNOWLEDGE EXAMPLE ITEMS	174
SOCIAL STUDIES CONTENT DESCRIPTION AND ADDITIONAL SAMPLE ITEMS	177
SOCIAL STUDIES ADDITIONAL SAMPLE ITEM KEYS	206
<b>APPENDIX A: LANGUAGE PROGRESSIVE SKILLS, BY GRADE</b>	<b>212</b>
<b>APPENDIX B: CONDITION CODES</b>	<b>213</b>

# THE GEORGIA MILESTONES ASSESSMENT SYSTEM



## Dear Student,

This **Georgia Milestones Grade 8 Study/Resource Guide for Students and Parents** is intended as a resource for parents and students. It contains sample questions and helpful activities to give you an idea of what test questions look like on Georgia Milestones and what the Grade 8 End-of-Grade (EOG) assessment covers.

These sample questions are fully explained and will tell you why each answer is either correct or incorrect.

**Get ready—open this guide—and get started!**

## HOW TO USE THIS GUIDE

### *Let's get started!*

\* **Get it together!**

- This guide
- Pen or pencil
- Highlighter
- Paper

\* **Gather materials**

- Classroom notebooks
- Textbooks

\* **Study space**

- Find a comfortable place to sit.
- Use good lighting.
- Time to focus—no TV, games, or phones!

\* **Study time**

- Set aside some time after school.
- Set a goal—how long are you going to study?
- Remember—you cannot do this all at one time.
- Study a little at a time, every day.

\* **Study buddy**

- Work with a friend, sister, brother, parent—anyone who can help!
- Ask questions—it is better to ask now and get answers.
- Make sure you know what you need to do—read the directions before you start.
- Ask your teacher if you need help.

\* **Test-taking help**

- Read each question and all of the answer choices carefully.
- Be neat—use scratch paper.
- Check your work!



## PREPARING FOR TAKING TESTS

### Getting ready!



### Here are some ideas to think about before you take a test.

- Get plenty of rest and eat right. Take care of your body and your mind will do the rest.
- If you are worried about a test, don't be. Talk with a teacher, parent, or friend about what is expected of you.
- Review the things you have learned all year long. Feel good about it.
- Remember that a test is just one look at what you know. Your class work, projects, and other tests will also show your teachers how much you have learned throughout the year.

### Try your best!

## OVERVIEW OF THE END-OF-GRADE ASSESSMENT

### *What is on the End-of-Grade Assessment?*

- \* English Language Arts (ELA)
- \* Mathematics
- \* Science
- \* Social Studies

### TYPES OF ITEMS

- \* **Selected-response items**—also called multiple-choice
  - English Language Arts (ELA), Mathematics, Science, and Social Studies
  - There is a question, problem, or statement that is followed by four answer choices.
  - There is only ONE right answer, so read EACH answer choice carefully.
  - Start by eliminating the answers that you know are wrong.
  - Then look for the answer that is the BEST choice.
- \* **Constructed-response items**
  - English Language Arts (ELA) and Mathematics only
  - There is a question, problem, or statement but no answer choices.
  - You have to write your answer or work out a problem.
  - Read the question carefully and think about what you are asked to do.
  - In English Language Arts (ELA), go back to the passage to look for details and information.
  - You will be scored on accuracy and how well you support your answer with evidence.
- \* **Extended constructed-response items**
  - English Language Arts (ELA) and Mathematics only
  - These are similar to the constructed-response items.
  - Sometimes they have more than one part, or they require a longer answer.
  - Check that you have answered all parts of the question.
- \* **Extended writing prompt**
  - English Language Arts (ELA) only
  - There is a question, problem, or statement.
  - You may be asked to do more than one thing.
  - In English Language Arts (ELA), you will be asked to read two passages and then write an essay.
  - You will be scored on how well you answer the question and the quality of your writing.
  - Organize your ideas clearly.
  - Use correct grammar, punctuation, and spelling.
  - Support your answer with evidence from the text.

---

## DEPTH OF KNOWLEDGE

Test questions are designed with a Depth of Knowledge (DOK) level in mind. As you go from Level 1 to Level 4, the questions get more and more challenging. They take more thinking and reasoning to answer. You may have experienced these types of questions in your classroom as your teachers find ways to challenge you each day.

A Level 1 item may not require as much thinking as a Level 4 item—but that does not mean it’s easy.

A Level 4 item may have more than one part or ask you to write something.

Here is some information to help you understand just what a DOK level really is.

### **Level 1 (Recall of Information)**

- \* Identify, list, or define something.
- \* Questions may start with *who*, *what*, *when*, and *where*.
- \* Recall facts, terms, or identify information.

### **Level 2 (Basic Reasoning)**

- \* Think about things—it is more than just remembering something.
- \* Describe or explain something.
- \* Answer the questions “how” or “why.”

### **Level 3 (Complex Reasoning)**

- \* Go beyond explaining or describing “how and why.”
- \* Explain or justify your answers.
- \* Give reasons and evidence for your response.
- \* Make connections and explain a concept or a “big idea.”

### **Level 4 (Extended Reasoning)**

- \* Complex thinking required!
- \* Plan, investigate, or apply a deeper understanding.
- \* These items will take more time to write.
- \* Connect and relate ideas.
- \* Show evidence by doing a task, creating a product, or writing a response.

**Depth of Knowledge**

**Level 1—Recall of Information**

Level 1 asks you to identify, list, or define. You may be asked to recall *who*, *what*, *when*, and *where*. You may also be asked to recall facts and terms or identify information in documents, quotations, maps, charts, tables, graphs, or illustrations. Items that ask you to “describe” and/or “explain” could be Level 1 or Level 2. A Level 1 item requires that you just recall, recite, or repeat information.

Skills Demonstrated	Question Cues
<ul style="list-style-type: none"> <li>• Make observations</li> <li>• Recall information</li> <li>• Recognize formulas, properties, patterns, processes</li> <li>• Know vocabulary, definitions</li> <li>• Know basic concepts</li> <li>• Perform one-step processes</li> <li>• Translate from one representation to another</li> <li>• Identify relationships</li> </ul>	<ul style="list-style-type: none"> <li>• Tell who, what, when, or where</li> <li>• Find</li> <li>• List</li> <li>• Define</li> <li>• Identify; label; name</li> <li>• Choose; select</li> <li>• Compute; estimate</li> <li>• Express as</li> <li>• Read from data displays</li> <li>• Order</li> </ul>

**Level 2—Basic Reasoning**

Level 2 includes some thinking that goes beyond recalling or repeating a response. A Level 2 “describe” and/or “explain” item would require that you go beyond a description or explanation of information to describe and/or explain a result or “how” or “why.”

Skills Demonstrated	Question Cues
<ul style="list-style-type: none"> <li>• Apply learned information to abstract and real-life situations</li> <li>• Use methods, concepts, and theories in abstract and real-life situations</li> <li>• Perform multi-step processes</li> <li>• Solve problems using required skills or knowledge (requires more than habitual response)</li> <li>• Make a decision about how to proceed</li> <li>• Identify and organize components of a whole</li> <li>• Extend patterns</li> <li>• Identify/describe cause and effect</li> <li>• Recognize unstated assumptions; make inferences</li> <li>• Interpret facts</li> <li>• Compare or contrast simple concepts/ideas</li> </ul>	<ul style="list-style-type: none"> <li>• Apply</li> <li>• Calculate; solve</li> <li>• Complete</li> <li>• Describe</li> <li>• Explain how; demonstrate</li> <li>• Construct data displays</li> <li>• Construct; draw</li> <li>• Analyze</li> <li>• Extend</li> <li>• Connect</li> <li>• Classify</li> <li>• Arrange</li> <li>• Compare; contrast</li> </ul>



**Level 3—Complex Reasoning**

Level 3 requires reasoning, using evidence, and thinking on a higher level than Level 1 and Level 2. You will go beyond explaining or describing “how and why” to justifying the “how and why” through reasons and evidence. Level 3 items often involve making connections across time and place to explain a concept or a “big idea.”

Skills Demonstrated	Question Cues
<ul style="list-style-type: none"> <li>• Solve an open-ended problem with more than one correct answer</li> <li>• Create a pattern</li> <li>• Generalize from given facts</li> <li>• Relate knowledge from several sources</li> <li>• Draw conclusions</li> <li>• Make predictions</li> <li>• Translate knowledge into new contexts</li> <li>• Compare and discriminate between ideas</li> <li>• Assess value of methods, concepts, theories, processes, and formulas</li> <li>• Make choices based on a reasoned argument</li> <li>• Verify the value of evidence, information, numbers, and data</li> </ul>	<ul style="list-style-type: none"> <li>• Plan; prepare</li> <li>• Predict</li> <li>• Create; design</li> <li>• Ask “what if?” questions</li> <li>• Generalize</li> <li>• Justify; explain why; support; convince</li> <li>• Assess</li> <li>• Rank; grade</li> <li>• Test; judge</li> <li>• Recommend</li> <li>• Select</li> <li>• Conclude</li> </ul>

**Level 4—Extended Reasoning**

Level 4 requires the complex reasoning of Level 3 with the addition of planning, investigating, applying deeper understanding, and/or developing that will require a longer period of time. You may be asked to connect and relate ideas and concepts *within* the content area or *among* content areas in order to be at this highest level. The Level 4 items would be a show of evidence—through a task, a product, or an extended response—that the higher-level demands have been met.

Skills Demonstrated	Question Cues
<ul style="list-style-type: none"> <li>• Analyze and synthesize information from multiple sources</li> <li>• Examine and explain alternative perspectives across a variety of sources</li> <li>• Describe and illustrate how common themes are found across texts from different cultures</li> <li>• Apply mathematical models to illuminate a problem or situation</li> <li>• Design a mathematical model to inform and solve a practical or abstract situation</li> <li>• Combine and synthesize ideas into new concepts</li> </ul>	<ul style="list-style-type: none"> <li>• Design</li> <li>• Connect</li> <li>• Synthesize</li> <li>• Apply concepts</li> <li>• Critique</li> <li>• Analyze</li> <li>• Create</li> <li>• Prove</li> </ul>

## ENGLISH LANGUAGE ARTS (ELA)

### DESCRIPTION OF TEST FORMAT AND ORGANIZATION

The Grade 8 English Language Arts (ELA) EOG assessment has a total of 60 items.

You will answer a variety of item types on the test. Some of the items are selected-response (multiple-choice), which means you choose the correct answer from four choices. Some items will ask you to write your response using details from the text. There will also be a writing prompt that will ask you to write an essay.

The test will be given in three sections.

- Sections 1 and 2 will be given on Day 1. You may have up to 75 minutes to complete each section.
- Section 3 will be given on Day 2. You will be given a maximum of 90 minutes to complete this section.

### CONTENT

The Grade 8 English Language Arts (ELA) EOG assessment will measure the Grade 8 standards that are described at [www.georgiastandards.org](http://www.georgiastandards.org).

The content of the assessment covers standards that are reported under these domains:

- Reading and Vocabulary
- Writing and Language

There are two kinds of texts—fiction (including stories and poems) and informational text.

There are two kinds of essays—an argumentative essay and an informational/explanatory essay.

Students will also write extended constructed responses that use narrative techniques such as completing a story, writing a new beginning, or adding dialogue. (Item 4 on page 27 gives an example of a prompt that requires a narrative response.)

### ITEM TYPES

The English Language Arts (ELA) portion of the Grade 8 EOG assessment consists of selected-response (multiple-choice), constructed-response, extended constructed-response, and extended writing response items.

## ENGLISH LANGUAGE ARTS (ELA) DEPTH OF KNOWLEDGE EXAMPLE ITEMS

Example items that represent applicable DOK levels are provided for you on the following pages. The items and explanations of what is expected of you to answer them will help you prepare for the test.

**All example and sample items contained in this guide are the property of the Georgia Department of Education.**

### Example Item 1

**DOK Level 1:** This is a DOK level 1 item because it requires students to recognize an infinitive and how it functions in the sentence.

**English Language Arts (ELA) Grade 8 Content Domain II:** Writing and Language

**Standard:** ELAGSE8L1a. Demonstrate command of the conventions of standard English grammar and usage when writing or speaking. a. Explain the function of verbals (gerunds, participles, infinitives) in general and their function in particular sentences.

**How does the underlined phrase function in the sentence?**

Because field trips are educational, the class wanted to visit the museum.

- A. verb
- B. subject
- C. direct object
- D. predicate nominative

**Correct Answer:** C

**Explanation of Correct Answer:** The correct answer is choice (C) direct object. The words *to visit* are an infinitive, which functions as a noun. In this sentence, they are the direct object of the verb *wanted*. Choice (A) is incorrect because *wanted* is the verb in this sentence, though *visit* can function as a verb in other sentences. Choice (B) is incorrect because *class* is the subject of the sentence. Choice (D) is incorrect because the sentence does not contain a verb of *being*.

To answer Example Items 2 through 4, you will read two passages about Houdini. What roles do both natural talent and hard work play in achieving a goal? You will answer two questions and then write an informational essay about having a goal and the steps you need to take to realize that goal.

Before you begin planning and writing, read these two passages:

1. Show Me Impossible
2. Houdini

As you read the passages, think about what details from the passages you might use in your informational essay.

Read these two passages about Houdini and answer Example Items 2 through 4.

### Show Me Impossible

It was barely 5 A.M. when Daniel left his two-room apartment on the Lower East Side of New York City and headed uptown. He had read yesterday's newspaper with excitement. Stories about Houdini had been plastered on the front pages of the papers for weeks—ever since his last show when he was handcuffed, then nailed inside a packing crate, and subsequently thrown into the river. Harry Houdini, the most sensational escape artist of all time, not only survived the incident, but swam to the surface in record time, where he was greeted by a crowd of cheering fans.

Daniel knew he had to see him, and the escape artist's next show was near enough for Daniel to attend. So Daniel got on the train especially early in the morning to make sure he was there before anyone else. He had heard about the crowds that came to Houdini's performances. He was not only determined to be there himself, but he was going to secure a seat in the first row.

"This man," Daniel had read earlier that week in the paper, "is a marvel. Either he has superhuman strength and skill, or he's an exceptionally clever illusionist. Either way, he's the most daring performer the world has ever seen." *Illusionist*—the word grabbed him. He whispered it quietly, forming the syllables with his lips. Then he said it out loud. "Illusionist." He loved the way it rolled off his tongue.

It certainly was not a word that was familiar in Daniel's world. In 1924, you were expected to remain grounded in reality, the polar opposite of illusion. Daniel thought about his former schoolteacher, Mrs. Thorpe, and the lessons she taught stressing that everything was explainable by science. Once he had chosen a fantasy novel from the library to read just for fun, but Mrs. Thorpe discouraged it. "I prefer that you choose a sensible book," she said. "That book is nothing more than nonsense."

She most likely would assert that Houdini was nothing but nonsense, too, Daniel thought. Houdini made the impossible happen—an illusionist can do that. An illusionist allows people to see the impossible—or what they presume to be impossible. Houdini was making believers out of the millions who saw him perform, believers in the impossible.

Daniel had looked up the word in a dictionary. "Illusionist." Houdini created illusions—he was a master at tricks of the eye. This man had been sealed inside a giant football and the carcass of a giant squid. He had been strapped in a straightjacket and hung by his ankles from the tops of tall buildings. The dictionary defined illusionist as "a person who performs tricks that deceive the eye." Mrs. Thorpe had used that term, "deceive the eye," in a science lesson. Daniel just knew that he had to see Houdini so that this daring illusionist could make him a believer, too.

## Houdini

In 1928, a man and an elephant stood in the center of the Hippodrome Theater's stage in the heart of New York City. As a spotlight beamed down upon them, the man raised his arm high in the air, a popping sound was heard, and in a flash, Jennie, the 10,000-pound elephant, suddenly disappeared. All that was left standing on the stage was the man alone. The elephant had vanished into thin air. And the man standing on the stage was Harry Houdini.

Houdini was born Erik Weisz in Budapest, Hungary. Upon immigrating to the United States, he first took up residence in Appleton, Wisconsin. He later became a circus entertainer performing trapeze acts. However, when the circus traveled to New York City, he knew it to be the right place for a performer.

He had a smattering of success in vaudeville, but eventually found his way into escape performances. It seemed that he had a great talent for picking locks, and that led to other feats—escapes from trunks, straightjackets, and even coffins. The phrase “They do it with mirrors” was applied to Houdini many times. Disbelievers felt that he was little more than an illusionist, a trickster. They accused him of deceit, stating that he cheated with trap doors or only appeared to be nailed in a box or locked in chains.

However, the unglamorous truth was that Houdini was a superb physical being with some enormous talents. For instance, he could hold his breath for an extraordinary amount of time. Additionally, he was strong and determined. When being tied up or bound in a straightjacket, he would fill his lungs to capacity and flex his muscles. That way he could gain a few millimeters of free space which would enable his forthcoming escape. He was not afraid to dislocate joints, such as a shoulder, or even rip flesh pulling an arm or a hand free of bindings. He might conceal a piece of metal under his tongue and use it to pick a lock. But free himself he would, and he did it without mirrors or any other kind of magic.

Despite the accusations of deception, Houdini remained popular with the American public. He continued to dream up more and more dangerous stunts, and people flocked to see them. No matter what people believed about him, he always escaped in the most straightforward way. He unlocked the locks, he got free of the chains, he made a tiny space in a lid into a bigger space. He used talent, strength, and resourcefulness, without any trickery.

## Example Item 2

**DOK Level 2:** This is a DOK level 2 item because the meaning of the word is based on the context of the passage.

**English Language Arts (ELA) Grade 8 Content Domain I:** Reading and Vocabulary

**Genre:** Literary

**Standard:** ELAGSE8RL4. Determine the meaning of words and phrases as they are used in a text, including figurative and connotative meanings; analyze the impact of specific word choices on meaning and tone, including analogies or allusions to other texts.

**Read these sentences from “Show Me Impossible.”**

*Illusionist*—the word grabbed him. He whispered it quietly, forming the syllables with his lips. Then he said it out loud. “*Illusionist*.” He loved the way it rolled off his tongue.

**Which definition of the word *grabbed* BEST conveys the meaning the word has in the first sentence?**

- A. captured
- B. caught
- C. fascinated
- D. seized

**Correct Answer:** C

**Explanation of Correct Answer:** The correct answer is choice (C) fascinated. The paragraph makes clear that Daniel is enchanted, or fascinated, by the word. Choices (A), (B), and (D) are incorrect because they do not convey the meaning the author intended. Choice (A) is close in meaning but does not match the intensity of how the word makes Daniel feel. Choices (B) and (D) are incorrect because, while they are valid definitions, they do not explain the connotation of the word as the author is using it in this sentence.





### Scoring Rubric

Points	Description
2	<p>The exemplar shows a full-credit response. It achieves the following:</p> <ul style="list-style-type: none"> <li>• Gives sufficient evidence of the ability to explain how a paragraph in a text helps to develop and refine a key concept within the text</li> <li>• Includes specific examples/details that make clear reference to the text</li> <li>• Adequately explains the development of concepts based on the text</li> </ul>
1	<p>The exemplar shows a 1-point response. It achieves the following:</p> <ul style="list-style-type: none"> <li>• Gives limited evidence of the ability to explain how a paragraph in a text develops and refines a key concept within the text</li> <li>• Includes vague/limited examples/details that make reference to the text</li> <li>• Explains the development of concepts based on the text</li> </ul>
0	<p>The exemplar shows a response that would earn no credit. It achieves the following:</p> <ul style="list-style-type: none"> <li>• Gives no evidence of the ability to explain how a paragraph in a text develops and refines a key concept within the text</li> </ul>

### Exemplar Response

Points Awarded	Sample Response
2	<p>Paragraph 4 explains Houdini the man and the idea that he was able to perform these tricks because he was strong and clever. He knew what he was doing and had ways to escape that were planned out in advance and did not rely on magic or illusions. They were real feats of strength. This paragraph is important because it takes away the mystery surrounding Houdini. Houdini would fill his lungs with air or hide a metal pick under his tongue. This proves that he was not really performing magic—he had figured out ways to escape from the most difficult physical situations.</p>
1	<p>Paragraph 4 explains that Houdini had figured out how to escape and make it seem like magic or illusions. You learn about this when you read this paragraph. For example he could hold his breath for a long period of time. He was really not a magician. He knew what to do.</p>
0	<p>Paragraph 4 talks about Houdini. He was strong.</p>

### Example Item 4

**DOK Level 4:** This is a DOK level 4 item because it requires analyzing and synthesizing information from different sources. Students must combine ideas from the two passages and write an essay that builds on what was read and explains something new.

**English Language Arts (ELA) Grade 8 Content Domain II: Writing and Language**

**Genres:** Literary and Informational

**Standard:** ELAGSE8W2. Write informative/explanatory texts to examine a topic and convey ideas, concepts, and information through the selection, organization, and analysis of relevant content.

**Now that you have read “Show Me Impossible” and “Houdini,” create a plan for and write your informational essay.**

### WRITING TASK

Many people have goals such as Houdini did. Think about ideas, facts, definitions, details, and other information and examples you want to use. Think about how you will introduce your topic and what the main topic will be for each paragraph. Be sure to identify the sources by title or number when using details or facts directly from the sources.

Write an informational essay about having a goal and the steps needed to realize that goal.

Be sure to use information from BOTH passages. **Write your answer on the lines provided.**

**Before you write, be sure to:**

- Think about ideas, facts, definitions, details, and other information and examples you want to use.
- Think about how you will introduce your topic and what the main topic will be for each paragraph.
- Develop your ideas clearly and use your own words, except when quoting directly from the passages.
- Be sure to identify the passages by title or number when using details or facts directly from the passages.

**Now write your informational essay. Be sure to:**

- Introduce the topic clearly, provide a focus, and organize information in a way that makes sense.
- Use information from the two passages so that your essay includes important details.
- Develop the topic with facts, definitions, details, quotations, or other information and examples related to the topic.
- Use appropriate and varied transitions to connect ideas.
- Clarify the relationships among ideas and concepts.
- Use clear language and vocabulary.
- Establish and maintain a formal style.
- Provide a conclusion that follows from the information presented.
- Check your work for correct usage, grammar, spelling, capitalization, and punctuation.



**The following is an example of a seven-point response. See the seven-point, two-trait rubric for a text-based informational/explanatory response on pages 66 and 67 to see why this example would earn the maximum number of points.**

**Example of a Seven-Point Response:**

*It is important to have goals and to work toward achieving them. Some people may be lucky and have a natural talent for doing something. But others have to work hard and plan or train to achieve their goal.*

*Houdini had a goal of being an escape artist and capturing the imagination of his audiences with his feats. He had natural skills that he practiced and perfected. In the second passage, we see that Houdini's ability to perform illusions and escapes were based in great part on his physical skills. For example, it was his unusual strength, in addition to practice, that enabled him to escape a straightjacket. His strength and physique allowed him to enlarge his chest cavity and his muscles sufficiently in order to have a bit of free space later, when it was time to free himself. Perfecting this escape, though, must have taken a great deal of training and practice.*

*Other people who dream of achieving Houdini-like feats, however, like Daniel in the first passage, might have to work a lot harder. There is no mention of Daniel having the natural abilities that Houdini had, and it is not likely that many people would have that natural talent. People like Daniel would have to train longer and harder in order to learn how to become an illusionist.*

*Any dream or goal requires a combination of natural ability and hard work. If you have a dream or goal, you should first see what talents you may have to help that dream come true. Then you should work hard and train to make it happen. It is probably more important to have some natural talents to develop, but training should help as well. Both are an important part of reaching your goal.*

---

## ENGLISH LANGUAGE ARTS (ELA) CONTENT DESCRIPTION AND ADDITIONAL SAMPLE ITEMS

In this section, you will find information about what to study in order to prepare for the Grade 8 English Language Arts EOG assessment. This includes key terms and important vocabulary words. This section also contains practice questions, with an explanation of the correct answers, and activities that you can do on your own, with your classmates, or with your family to prepare for the test.

**All example and sample items contained in this guide are the property of the Georgia Department of Education.**

### Unit 1: Reading Literary Text

#### READING PASSAGES: LITERARY TEXT

##### CONTENT DESCRIPTION

The literary passages in the English Language Arts (ELA) test are used to identify main ideas and details, cite evidence, make inferences, determine themes, and understand vocabulary.

##### Key Ideas and Details

- Ideas and details tell you what the story or poem is about.
- Use these ideas and details when writing or speaking about the story or poem.
- Look for central ideas or themes as you read. Ask yourself—what is this about?
- Think about the characters, setting, and events in the story.
- Summarize the important details and ideas after you read.

##### Structure of the Text

- Make sure you understand the words and phrases as you read.
- Think about how specific words can help you understand the meaning or tone.
- Look at the structure of stories. Pay attention to how the parts of the text (e.g., a section, chapter, scene, or stanza) work with each other and the story or poem as a whole.
- Think about the point of view or purpose of a text.

##### Understanding What You Read

- Think about the story and visualize, or make a mental picture, as you read.
- Think about the message or what the writer is trying to say.

## KEY TERMS

**Inference:** To infer means to come to a reasonable conclusion based on evidence found in the text. By contrast, an **explicit** idea or message is fully stated or revealed by the writer. The author tells the reader exactly what they need to know. (RL1)

**Theme:** The theme of a literary text is its lesson or message. For example, a story could be about two friends who like to do things together, and the theme might be the importance of friendship. (RL2)

**Plot:** The series of events that form a story in a specific order. (RL3)

**Resolution:** In most stories there is a conflict or problem. The resolution is the solution to the problem or the end of the main dramatic conflict. (RL3)

**Allusion:** An indirect reference to something. When a writer refers to something without mentioning it explicitly, it is an allusion. For example, *He didn't want to give gifts to anyone at Christmas; he was being a scrooge.* In this sentence, the writer is alluding to Ebenezer Scrooge from Charles Dickens' *A Christmas Carol*. (RL.4)

**Figurative language:** To understand figurative language, you need to distinguish between literal and figurative meanings of words and phrases. Literal refers to the actual meaning of a word or phrase. For example, if someone tells you to open the door, you can open a physical door. If someone tells you to "open the door to your heart," you are opening up your feelings and emotions.

- **Personification:** When a writer describes an object as if it were a person. For example, *The trees sighed in the afternoon breeze.* The trees cannot really sigh but seemed to as they blew gently in the breeze. (L5a)
- **Simile:** A comparison using *like* or *as*. For example, *She is as pretty as a picture.* (L5a)
- **Metaphor:** A direct comparison that states one thing *is* another. It isn't meant to be literal, but descriptive. For example, *He is an animal on the soccer field* does not mean that the boy is really an animal, but it is a metaphor for how he plays soccer (very aggressively). (RL.4)

Examples of figurative language are similes and metaphors. **Similes** make a comparison using a linking word such as *like*, *as*, or *than* (her eyes shone like the stars). A **metaphor** makes a comparison without a linking word; instead of being *like* another, one thing *is* another (her eyes *were* shining stars). (RL4)

**Alliteration:** The use of the same sound to start several words in a row. For example, *The beautiful butterfly blew by the bay.* Literary devices such as alliteration can have a big impact on poems, stories, and dramas. (RL4)

**Point of view:** The perspective from which a story is told. The point of view depends upon who the narrator is and how much he or she knows. The point of view could be first person (*I* went to the store), second person (*You* went to the store), or third person (*He* went to the store). (RL6)

**Compare vs. contrast:** Though similar, comparing is analyzing two things such as characters or stories in relation to each other, while contrasting is specifically analyzing the *differences* between two things, such as two different characters or stories. (RL7/RL9)

**Genre:** A **genre** is a category of passages, such as fiction and nonfiction. Each genre has a particular style, form, and content. (RL9)

### **Important Tips**

- ✍ Use supporting ideas and concepts to answer *what* you know and *how* you know it.
- ✍ Try to answer the question before you read the answer choices.
- ✍ Try to read the questions about a literary text before you read.
- ✍ Re-read a literary text as you answer the questions to gain a better understanding.

## Sample Items 1–4

Use this passage to answer questions 1 through 4.

### Pony Express

The low morning sun stretched across the hotel dining room as a young cowboy walked toward the lone occupant. Shafts of light shone through the dust, producing golden bands not quite parallel to the floor. Holding his new Stetson hat respectfully at his side, the cowboy walked toward him. The man noted his approach, rose, and extended his hand. “Ah, Mr. Sewell, I presume. I’m Derek Bollinger.” Caleb Sewell was taken off guard at being addressed as Mister, especially by a man wearing a suit that Caleb couldn’t afford with the wages of his last month’s work.

“Yep. Howdy.” The words were out automatically, and Caleb immediately regretted his lack of formality as he shook the man’s hand and sat down. He fidgeted with his hat, not knowing where it should go, but certain that it couldn’t go back on his head. Bollinger, sensing his discomfort, pulled out one of the empty chairs and nodded to it.

“In the interest of saving valuable time, Mr. Sewell, I’ve ordered for us both.” Caleb nodded approval and restrained himself from saying something silly like, “Aw, that’s right neighborly of ya.” A waitress filled his coffee cup. To avoid embarrassment, he added only about half his usual amount of sugar. He watched the expensively dressed man for clues as to what to do with his stirring spoon, how to hold the delicate cup, and where to put his napkin.

Mercifully, two orders of steak, eggs, beans, and sourdough biscuits arrived before any more pauses set in. Eating made it easier for Caleb to avoid talking, though he continued to watch Bollinger’s actions closely. The man began enumerating Caleb’s responsibilities as a Pony Express rider. Mail, he said, was a precious commodity. It both connected and fulfilled lives on each end of the route. He must never exhaust the horses; he would ride six or seven each day, and they were the lifeline of the whole enterprise. He should report conditions on the trail—fallen trees, landslides, washed out bridges—at the nearest transfer station. He was to ride alone except when an escort with the local law was arranged. He would have protection on the Humboldt Pass section where robberies had become frequent of late.

Caleb had been briefed on most of this when he filled out an application back home in Wheeling, so the best information he took from Bollinger was that it was acceptable to sop his bean juice with a biscuit. Bollinger did all of the talking. To Caleb’s great relief, Bollinger did not ask what had brought a man out to the wilds of the frontier when he could have enjoyed the security of working in the family business as part of a comfortably successful family in the quiet state of West Virginia. He didn’t know how to explain what a burden it was to have a family that wanted to determine how the rest of your life should proceed. He had no words to explain their disappointment at his wanting to chart his own course, not to mention how effortlessly he’d settled into a life on the plains.



At length, the man stood, shook hands with Caleb a last time, and told him he was to pick up his horse and packet of mail at the livery stable. “Good to have you with us on the Pony Express, Mr. Sewell. We have begun forging a strong tradition throughout the West and the nation. Now, do us and yourself proud.” Caleb bent down, retrieved his hat from the chair, and when he stood back up, Bollinger was gone.

The handlers were ready for him at the stable. Two saddlebags straddled a bar outside a box stall that said “Pony Express Only.” In the stall, his own personal saddle was already on a small Appaloosa. The horse shifted and paced nervously, a sign that he’d been given a more than ample breakfast of oats. Caleb led the horse into the street and was tightening the cinch of the saddle when a clerk came up to him with a delivery log. Caleb signed it, secured the saddlebags, and threw his leg up over the saddle. The horse bolted for the open road, but Caleb’s deft touch convinced the horse of the pace they would maintain.

Caleb Sewell’s first day as a Pony Express rider had begun. It would end twelve hours and eighty miles later.

## Item 1

**Which detail from the passage indicates that Caleb is self-conscious?**

- A. The low morning sun stretched across the hotel dining room as a young cowboy walked toward the lone occupant.
- B. Holding his new Stetson hat respectfully at his side, the cowboy walked toward him.
- C. He fidgeted with his hat, not knowing where it should go, but certain that it couldn’t go back on his head.
- D. He was to ride alone except when an escort with the local law was arranged.

## Item 2

Read the sentence from the passage.

Mercifully, two orders of steak, eggs, beans, and sourdough biscuits arrived before any more pauses set in.

In what way is the arrival of food a *merciful* event?

- A. Caleb was in need of food because he had not been making much money.
- B. Caleb was less likely to embarrass himself while he was busy eating.
- C. The Pony Express delivered meals to those who were going hungry.
- D. The breakfast was provided free of charge to Pony Express riders.

## Item 3

Which detail would be **BEST** to include in a summary of the passage?

- A. A waitress filled his coffee cup.
- B. He should report conditions on the trail.
- C. At length, the man stood and shook hands with Caleb a last time.
- D. His own personal saddle was already on a small Appaloosa.

**Item 4**

Based on the information in the passage, write a continuation of the passage that reveals Caleb’s inner dialogue, or his thoughts, as he begins riding his first Pony Express route.

Support your response with details from the passage. Write your answer on the lines provided.

A large rectangular box containing 20 horizontal lines for writing a response.

## Unit 2: Reading Informational Text

### READING PASSAGES: INFORMATIONAL TEXT

#### CONTENT DESCRIPTION

The informational and explanatory passages in the English Language Arts test can be used to determine central ideas, write an objective summary, analyze ideas, and provide supporting text evidence.

#### Key Ideas and Details

- Read closely to know exactly what the text says.
- Look for details that tell what the text is about.
- Use those details when writing or speaking about the text.
- Look for the central ideas in the text.
- Summarize the important details and ideas.
- Think about how ideas develop and work together in the text.

#### Structure

- Make sure you understand the words in the text.
- Use a dictionary, thesaurus, or glossary to help you with words that are new.
- Look at how the parts of the text work with each other.
- Think about the author's point of view or purpose in the text.

#### Understanding the Text

- Think about the text as if it were presented as a movie or a television show.
- Think about the text and its message.
- Look for details or evidence in the text.

## KEY TERMS

**Summary:** A summary is an overview of a text that captures the main points but does not give all of the details and does not include opinions. (RI2)

**Interactions:** How ideas influence individuals or events or how individuals influence ideas or events. As one analyzes the interactions in a text, they give insight into the meaning. (RI3)

**Connotative meaning:** A meaning beyond the explicit meaning of a word. For example, the word *childlike* connotes innocence as well. Connotations are meanings inferred from certain words. (RI4)

**Denotative meaning:** The explicit meaning of a word. For example, *helpful* has only one meaning and connotation, which is to be of service or assistance. (RI4)

**Organization:** The way in which a piece of writing is structured. Each sentence, paragraph, or chapter fits into the overall structure of a text and contributes to the development of ideas. (RI5)

**Author's purpose:** The author's intention for his or her piece. All passages have a purpose, whether it is to persuade, inform, explain, or entertain. (RI6)

**Author's point of view:** The opinion of the author. Your opinion may differ from the opinion of the author writing a passage. (RI6)

**Evidence:** Something that proves or demonstrates the truth of something else. Informational texts may contain evidence to prove that the information they are providing is correct. (RI8)

**Fact and opinion:** A **fact** is a statement that can be proven. An **opinion** is a statement that cannot be proven because it states a writer's belief or judgment about something. Deciding whether or not a statement is a fact or an opinion often comes down to a single question: "Can you prove it?" If you can prove a statement, then it is a fact. If not, it's an opinion. (RI2)

**Chronological order:** The order in which a series of events happened. A text that is arranged in order of time from the beginning to the end is in chronological order. (RI5)

**Cause and effect:** This is a relationship where one thing causes another thing to happen. A passage may also be organized by stating the **problem and solution** as well. (RI3)

### Important Tips

- ✍ Try to read the questions about an informational text before you read the text so that you know what to look out for.
- ✍ Use evidence from a passage to help explain what is being said.
- ✍ Use facts and details to support ideas and answer *what* you know and *how* you know it.

## Sample Items 5–8

Read the following passage and answer questions 5 through 8.

### Living in the Darkness under the Sea

Marine biologists patrol an undersea world that resembles a rocky landscape more than it does an ocean floor. The scientists cruise through the water in a remote-controlled submarine in complete darkness. If they shine a light, what they see is something totally unexpected: tall rock formations jutting up from the ocean floor and surrounded by black smoke, similar to underwater chimneys. Circling these rocky peaks are worm-like organisms. They resemble red-and-white tubes—like giant peppermint sticks. What is even more amazing is that these odd creatures are not only alive, but living in this dark underworld away from light and the sun’s energy. So how is that possible?

Underwater vents somehow create an environment where these striped creatures can exist. Ever since the discovery of the creatures in 1977, scientists have been both baffled and intrigued by the very existence of these strange creatures that grow out of vents on the ocean floor away from sunlight.

What scientists have learned is that there are large cracks, or vents, in the ocean floor where these creatures exist. These deep-sea vents can be compared to the kinds of geysers you see on land. But, instead of shooting up from the ground, they shoot up from the bottom of the ocean floor. According to the National Oceanographic and Atmospheric Administration (NOAA), the billowing black smoke that exists on the ocean floor is probably the result of hot liquids bursting from the vents and mixing with the extremely cold ocean water.

What is so shocking about this information? Well, scientists always believed that life on Earth could not exist without sunlight. Yet somehow energy is being released below the surface of the water, and all without the benefit of the sun. It’s as if these undersea vents have created a unique ecosystem, deriving energy from Earth itself.

Scientists even have named the underwater creatures. They are called *extremophiles*—a fancy name for organisms that live in an extreme environment in the ocean vents. Scientists continue to study extremophiles to determine just how the creatures turn these vents into sources of usable energy.

**Item 5**

Which detail from the passage BEST supports the conclusion that the deep-sea organisms described in the passage may have changed our understanding of life?

- A. tall rock formations jutting up from the ocean floor and surrounded by black smoke
- B. These odd creatures are not only alive, but living in this dark underworld away from light.
- C. large cracks, or vents, in the ocean floor where these creatures exist
- D. Energy is being released below the surface of the water.

**Item 6**

Which of these BEST expresses the meaning of *deriving* in the sentence?

It's as if these undersea vents have created a unique ecosystem, deriving energy from Earth itself.

- A. depositing
- B. emptying
- C. extracting
- D. wasting





**Item 8**

**What is the central idea of the passage?**

**Support your response with details from the passage. Write your answer on the lines provided.**

A large rectangular box containing 25 horizontal lines for writing an answer.

## Unit 3: Writing Informational/Explanatory Texts

### CONTENT DESCRIPTION

The informational/explanatory passages in the English Language Arts test help develop your writing. Informational writing states ideas, summarizes research, and uses information from more than one source.

### Text Types and Purposes

- Write informational/explanatory texts to state ideas and information clearly and accurately.
- Use the best details, organize them, and explain them when necessary.

### Production and Distribution of Writing

- Produce writing with organization and style that fits the task, purpose, and audience.
- Develop and strengthen writing by planning, revising, editing, rewriting, or trying a new approach.
- Use technology, including the Internet, to produce and share writing.

### Audience, Purpose, and Voice

- As you write, remember who your audience will be.
- Make sure your writing is appropriate. Watch your tone, style, and voice.
- Remember, you are writing for a purpose—think about *what* you are writing and *why*.

### Range of Writing

- Write routinely over extended time frames (time for research, reflection, and revision) and shorter time frames (a single sitting or a day or two) for a range of tasks, purposes, and audiences.

### Scoring Rubrics

- Scoring rubrics can be found beginning on page 63. You may find it helpful to read and discuss these with a parent or another adult.
- The rubrics show you what is needed to produce a strong piece of writing.
- Rubrics are important to understand. They tell you what to add to your writing.
- Writing on the EOG assessment will be scored using these rubrics.

## KEY TERMS

**Informational/explanatory texts:** A form of writing that informs the reader or explains something. (W2d)

**Introduction:** The beginning of a piece of writing. The introduction should let readers know what they will be reading about and set up the main idea of the writing. (W2a)

**Organization:** The way in which a piece of writing is structured. Similar ideas and illustrations should be grouped together, and the order of the information should make sense. (W2a/W4)

**Transition:** A word, phrase, or clause that links one idea to the next. Writing should not jump from one idea to the next without transitions that guide the reader to the next idea. Examples include words such as *another*, *for example*, *also*, and *because*. (W2c)

**Conclusion:** The end of a piece of writing is the conclusion. The conclusion should sum up the main idea of the writing and provide an overall message for the reader. (W2f)

**Formatting:** The way in which a piece of writing is organized. For example, a writer can use headings and subheadings to organize the writing and present the information in a clear way. (W2a)

**Multimedia:** A variety of mediums. Writing does not only include pen on paper or a typed essay. Other ways of enhancing writing can include mediums such as art, presentations, photographs, charts, videos, and more. (W2a)

**Writing Process:** Most informational or technical pieces require hard work and revision before they can be considered ready. Even professional writers may struggle with their words. Drafting, revising, editing, and proofreading your writing are all essential parts of an effective writing process. The steps in the writing process are prewriting, drafting, revising and editing, proofreading, and publishing. (W5)

### Important Tips

- ✍ Begin by organizing your ideas in different sections. You can use a graphic organizer such as a chart or Venn diagram, or you can create an outline of your writing. Then it will be easier to fill in the supporting details.
- ✍ Be sure to develop your writing with details such as facts, definitions, quotations, or other information that supports your topic.
- ✍ Organize your writing by using chronological order, cause and effect, compare and contrast, or asking and answering questions.
- ✍ Make sure your writing has a concluding statement that supports your central idea.
- ✍ Strengthen your writing by planning, revising, editing, rewriting, or trying a new approach.

### Sample Items 9–12

[**NOTE:** The structure of the practice items for this unit and Unit 4 that follows is as it appears on the Georgia Milestones End-of-Grade assessment: 1) multiple-choice questions (three on the actual test); 2) a constructed-response item; and 3) an extended writing prompt. Additionally, the instructions for the extended writing prompt are in a format that is similar to the one on the End-of-Grade assessment. There is no extended writing prompt in this unit.]

**In this section, you will read a passage and answer questions 9 through 12. You will read about the status of pandas in China and how their presence affects the economy and tourism of China. You will answer four questions about the passage.**

Read the following passage and answer questions 9 through 12.

## Panda Economics

One of the most easily recognizable faces in the animal kingdom is that of the giant panda. That large, round, white face with the big black patches around the expressive eyes consistently warms hearts around the globe. But how much do you really know about the panda and the interesting relationship that exists between pandas and their homeland?

### Endangered Pandas

As you probably know, pandas are those endangered, 250-pound, black-and-white bears living in the remote mountain areas of central China. They are slow-moving animals who divide their day between eating and resting and little else. It is estimated that there are about 1,000 to 1,500 pandas still living in the wild and maybe another 100 to 200 living in zoos around the world. Pandas primarily eat bamboo shoots and excel at tree climbing. They spend at least half of their day pulling bamboo off the trees. They can eat almost thirty pounds in a day. That's quite an appetite. But pandas do more than just ingest the bamboo. Their gathering and chewing actually spreads bamboo seeds around, which in turn helps more trees to grow.

### Saving the Panda through Ecotourism

What you may not know is how pandas and China help one another through *ecotourism*. Think of that term as a combination of *ecology* and *tourism*. In everyday language, it's a lot like saying, "If you vacation here, you will be helping the environment." The Chinese government has done much to protect the beloved pandas. It has built natural habitats for the pandas to live in. These are places where they can rest, chomp away on bamboo, and live in a protected environment. And all this resting and chomping attracts tourists to China. Obviously, the pandas benefit, but the money the tourists spend on their tour is money in China's pocket. People from around the world travel to China to visit and observe the pandas in these habitats. So pandas become a significant source of revenue for the country. At a time the country is spending money to protect them, the pandas, in a sense, repay their country.

Pandas also help the Chinese economy in other ways. Pandas are loaned to zoos around the world for upwards of a million dollars a year. Pandas are big business for zoos, as people flock to see them and spend money in the process. And the money that is paid for the loan of the pandas is then used to help maintain the habitats where the pandas live.

The relationship between pandas and ecotourism is a fascinating one. There's always the risk that bringing tourists to natural habitats will result in the destruction of those habitats. But for now, the pandas are at peace, dining on bamboo, and their habitats are protected, with tourism dollars providing support.

### Item 9

Read these sentences from paragraph 2.

They spend at least half of their day pulling bamboo off the trees. They can eat almost thirty pounds in a day. That's quite an appetite. But pandas do more than just ingest the bamboo.

Which words **BEST** replace *ingest* without changing the meaning of the sentence?

- A. grab onto
- B. almost ruin
- C. hungrily eat
- D. lightly nibble

### Item 10

Which sentence **BEST** explains the central idea of the passage?

- A. The panda population is declining.
- B. Pandas are endangered and need help.
- C. Ecotourism encourages travel to a foreign country.
- D. Ecotourism helps pandas and the national economy.

**Item 11**

The author of this passage would like to add another paragraph with the heading “The Other Side of Ecotourism.” Where should the author place the new paragraph? Explain why.

Support your response with details from the passage. Write your answer on the lines provided.

A large rectangular box containing 20 horizontal lines for writing a response.

**Item 12**

What is the MAIN connection between the section “Endangered Pandas” and the section “Saving the Panda through Ecotourism”?

Support your response with examples from the passage. Write your answer on the lines provided.

A large rectangular box containing 20 horizontal lines for writing an answer.



---

## Unit 4: Writing Argumentative Texts

### CONTENT DESCRIPTION

The argumentative passages in the English Language Arts test help you develop arguments and claims and support a point of view on a topic. In your writing, use evidence, examples, quotations, and reasons to develop and support your claims and arguments.

### Purpose

- An argumentative piece takes a stand or agrees or disagrees with a point of view.
- Some common words are *agree* or *disagree* or *for* or *against*.
- When you state your argument, you need to support it with claims, reasons, examples, and evidence.

### Editing Your Writing

- Check your writing for good organization.
- Make sure your writing fits the task, purpose, and audience.
- Strengthen your writing by planning, revising, editing, rewriting, or trying a new approach.
- Use technology, including the Internet, to do research.

### Scoring Rubrics

- Scoring rubrics can be found beginning on page 63. You may find it helpful to read and discuss these with a parent or another adult.
- The rubrics show you what is needed to produce a strong piece of writing.
- Rubrics are important to understand. They tell you what to add to your writing.
- Writing on the EOG assessment will be scored using these rubrics.

## KEY TERMS

**Claims:** Ideas and opinions set forth by the author. For example, a writer could make the claim that the school cafeteria food is too expensive. In a well-developed argumentative essay, the writer should also recognize alternate or opposing claims. (W1a)

**Evidence:** The reasons given to support a writer's claims. For example, a writer could include information on the price of school lunch or the number of students who do not want to buy it as reasons to support the claim that the school cafeteria is too expensive. (W1b)

**Relationships:** The ways in which ideas are connected. Writing should use words, phrases, and clauses to clarify the relationships among claims and reasons. (W1c)





**Purpose:** The writer's intention for his or her piece. All writing has a purpose, whether it is to persuade, inform, explain, or entertain. (W4)

**Audience:** The people who will be reading the piece of writing. Writers should keep their audience in mind and adjust their ideas and vocabulary so that they can be best understood. (W4)

**Organization:** In writing, the organization helps explain ideas and information more clearly. Writers use transitions to organize information. Also, an entire piece of writing has an organizational structure to it. Writers structure their texts to match their purpose and audience. For example, if you were writing an argumentative text in which you wanted to show the negative effects of something, you might choose cause and effect as an organizational structure. (W1a)

**Revision:** The process of editing and rewriting a piece of writing. All good writing requires a lot of revision in order to catch mistakes and clarify ideas. (W5)

### Important Tips

-  Make sure that the arguments you make in your writing have clear reasons and relevant evidence. The evidence must strongly support your claims.
-  Organize your writing by using chronological order, cause and effect, compare and contrast, or asking and answering questions.
-  Make sure your writing has a concluding statement that supports the information or explanation presented.
-  Always read over your writing several times to check your work and catch errors.

## Sample Items 13–16

[**NOTE:** The structure of the practice items for this unit is as it appears on the Georgia Milestones End-of-Grade assessment: 1) multiple-choice items (three on the actual test); 2) a constructed-response item; and 3) an extended writing prompt. Additionally, the instructions for the extended writing prompt are in a format that is similar to the one on the End-of-Grade assessment.]

**In this section, you will read two passages and answer questions 13 through 16.**

You will read about the debate about labeling menu choices with nutritional information.

Should there be a law that requires restaurants and fast food places to post nutritional information, including calories, fat content, and sodium, on their menus? Write an argumentative essay supporting either side of the debate in which you argue that labeling menu choices should become law OR that it should not.

Be sure to use information from BOTH passages. **Write your answer on the lines provided.**

**Before you begin planning and writing, you will read two passages and answer three questions about what you have read. As you read the passages, think about what details from the passages you might use in your argumentative essay. These are the titles of the passages you will read:**

1. Label the Meals
2. We Don't Need Labels

### **Label the Meals**

Our city has proposed that establishments selling meals—restaurants and fast-food places—post nutritional information on their menus or menu boards. For the good of our citizens, this measure must pass.

I'll start by making an obvious point, one that both sides should agree on. Healthy people are happier and more productive. One part of the healthy person equation is, of course, fitness, and that is clearly good for the individual. However, eating nutritious food is another part of that same equation. Labeling meals in restaurants is one sure way of helping people take charge of their well-being.

According to studies, the average American eats at home about two-thirds of the time. Over the last 25 years, the packaging of food to be consumed in the home has included nutritional information: calories, fat calories, sodium, calcium, and the like. It's the law to include this information on all packaging, regardless of whether the food is healthful or not. So it makes no sense to deny the consumer the same information when dining out.

Research shows that when such information is available, about one-quarter of customers use it to limit what they decide to eat. Those customers consume an average of 400 fewer calories than they typically did prior to labeling. Another study compared results in a nationwide coffee shop that also sold pastries. In some cities, the shops were required to post the calories for each item; in other cities, there was no such information. The average purchase contained about 100 fewer calories when the information was provided. The U.S. government agrees that restaurant meals should be labeled. It is part of the Affordable Care Act of 2010, which requires that standard menu items include information on nutrition.<sup>1</sup>

Eating out is on the rise. In 1977, Americans consumed 18% of their calories away from home. Less than 30 years later, that number had risen to 33%. It nearly doubled. This trend poses increased risks for all of us, not just in terms of calories, but in terms of unhealthful ingredients such as fat and sodium. Armed with relevant information, consumers can address this risk and be better for it.

We know the octane level of the fuel we put in our cars. We should know the relevant information about the fuel we put in our bodies. Please vote for labeling.

---

<sup>1</sup>[www.federalregister.gov](http://www.federalregister.gov)

## We Don't Need Labels

The proposal to require our community's eating establishments to post nutritional information for their meals is misdirected. It will not achieve any of the benefits its supporters claim.

First, the research claiming a reduction in caloric intake is, at times, contradictory. For instance, when researchers interviewed customers, they were told that the information caused them to select a "healthier" meal. However, when the cash register records were analyzed, there was no change from the way those same customers ordered previously. People may like the idea of nutritional labeling, but they still don't seem to be acting on it. I would suggest that those who claim to be reading and following the nutritional information actually need it the least. They are already health conscious. They have a good idea which meals are laden with calories, fats, and other ingredients. The Food and Drug Administration (FDA) not only requires food be labeled, but also provides the % Daily Value so that you can track the nutrients you are consuming.<sup>2</sup>

A good number of restaurant patrons are frequently looking for something other than a healthful eating experience. They are there for convenience, for a break in the routine, or for a special occasion. For these people, labeling is irrelevant.

But for the restaurant, it is a nuisance and a potential threat to their business. It means that before a new item goes on the menu, it has to be evaluated. It means that as recipes are modified and improved, more testing is needed. This is government inserting itself into business. Food should look good and taste good.

Foods for home consumption have been labeled for decades; but according to consumer research, that information has had a minimal effect on sales. What food producers have learned is that the overall packaging makes a far greater difference. The words "Lite," "Low fat," and "Heart Smart" do attract buyers. Restaurants are free to group selections according to reasonable health standards. This would probably mean more to the average consumer than trying to sort through the difference between 1350 calories and 1375 calories. Let's face it—the tastiest foods are the ones loaded with calories.

While labeling appears to promote healthful dining, its actual impact will most likely be minimal at best and harmful at worst.

---

<sup>2</sup>U.S. Food and Drug Administration ([www.fda.gov](http://www.fda.gov))

### Item 13

Read the paragraph from “Label the Meals.”

Research shows that when such information is available, about one-quarter of customers use it to limit what they decide to eat. Those customers consume an average of 400 fewer calories than they typically did prior to labeling. Another study compared results in a nationwide coffee shop that also sold pastries. In some cities, the shops were required to post the calories for each item; in other cities, there was no such information. The average purchase contained about 100 fewer calories when the information was provided. The U.S. government agrees that restaurant meals should be labeled. It is part of the Affordable Care Act of 2010, which requires that standard menu items include information on nutrition.

Which sentence would **BEST** support the writer’s argument when added to the paragraph?

- A. Families can choose to eat at home or go out.
- B. Coffee shops will be forced to stop selling baked goods.
- C. Customers can then decide to use or ignore the information.
- D. Restaurants will likely lose customers once the information is posted.

### Item 14

Read the sentences from “We Don’t Need Labels.”

It means that before a new item goes on the menu, it has to be evaluated. It means that as recipes are modified and improved, more testing is needed. This is government inserting itself into business. Food should look good and taste good.

Which sentence should be removed because it is **NOT** relevant to the argument?

- A. It means that before a new item goes on the menu, it has to be evaluated.
- B. It means that as recipes are modified and improved, more testing is needed.
- C. This is government inserting itself into business.
- D. Food should look good and taste good.

**Item 15**

Which revision to this sentence **BEST** maintains a formal style?

Let's face it—the tastiest foods are the ones loaded with calories.

- A. Just go for it, and tasty foods are always higher in calories.
- B. In fact, the tastiest foods may be the ones with the most calories.
- C. Seriously, those fattening foods can also really be the tastiest ones.
- D. No worries, the foods with the best taste are also the most fattening.

## Item 16

Now that you have read “Label the Meals” and “We Don’t Need Labels” and have answered some questions about what you have read, create a plan for and write your argumentative essay.

### WRITING TASK

You will read about the debate about labeling menu choices with nutritional information.

Should there be a law that requires restaurants and fast food places to post nutritional information, including calories, fat content, and sodium, on their menus? Write an argumentative essay supporting either side of the debate in which you argue that labeling menu choices should become law OR that it should not.

Be sure to use information from BOTH passages. **Write your answer on the lines provided.**

#### Before you write, be sure to:

- Think about ideas, facts, definitions, details, and other information and examples you want to use.
- Think about how you will introduce your topic and what the main topic will be for each paragraph.
- Develop your ideas clearly and use your own words, except when quoting directly from the passages.
- Be sure to identify the passages by title or number when using details or facts directly from the passages.

#### Now write your argumentative essay. Be sure to:

- Introduce your claim.
- Support your claim with logical reasoning and relevant evidence from the passages.
- Acknowledge alternate or opposing claims.
- Organize the reasons and evidence logically.
- Use words, phrases, and clauses to connect your ideas and to clarify the relationships among claims, counterclaims, reasons, and evidence.
- Establish and maintain a formal style.
- Provide a concluding statement or section that follows from and supports the argument presented.
- Check your work for correct usage, grammar, spelling, capitalization, and punctuation.





## Unit 5: Language

### CONTENT DESCRIPTION

The language portion of the English Language Arts test focuses on the use of proper grammar, punctuation, spelling, and usage.

#### Language

- You need to express yourself clearly and in an interesting way.
- Choose your words carefully so your readers understand what you are writing.
- Apply the rules of grammar as you write.

#### Conventions of Standard English

- Use correct grammar and usage when writing.
- Use correct capitalization, punctuation, and spelling.

#### Style

- Vary the words you use. Use a dictionary and thesaurus to help you.
- Your writing should be clear and interesting at the same time.
- Use colorful language and different sentence structures.

### KEY TERMS

**Punctuation:** Writing marks that help to separate and clarify ideas. Examples of punctuation are the period, comma, colon, dash, ellipsis, exclamation mark, and question mark. (L2)

**Participle:** A participle is based on a verb form that functions as an adjective within the sentence. Present participles typically end in *-ing* and past participles typically end in *-ed*. (L1a)

**Gerund:** A gerund is a present participle that is used as a noun. It can be the subject of a verb, the object of a verb, a predicate nominative or complement, or the object of a preposition. (L1a)

**Infinitive:** An infinitive is a phrase that consists normally of the word “to” followed by a verb. The phrase can act as a noun, adjective, or adverb within the sentence. Examples are *to swim*, *to learn*, and *to look*. (L1a)

**Active Voice:** A sentence uses active voice when the subject of the sentence performs the action expressed in the verb. This is a preferred construction for most writing to present ideas clearly and to avoid unnecessary wordiness. An example is *The girl caught the fish*. (L1b)

**Passive Voice:** A sentence uses passive voice when the subject of the sentence receives the action. An example of active voice is *The fish was caught by the boy*. (L1b)

**Indicative Verb:** The indicative verb is used to simply state a fact or opinion. (L1c)

**Imperative Verb:** The imperative verb is used to command or tell someone to take action. It is understood that you are the direct object of the imperative verb. Examples are *eat, sit, and be*. (L1c)

**Interrogative Verb:** An interrogative verb used when the author or speaker is asking a question. (L1c)

**Conditional Verb:** A conditional verb used when a situation is dependent on a particular condition. An example is *I would love to see you if you have some time available today*. (L1c)

**Subjunctive Verb:** A subjunctive verb that shows something that is contrary to fact. An example is *I wish we would have had dinner earlier*. (L1c)

**Context:** Words and phrases that surround another phrase and help to explain its meaning. Sometimes a word cannot be understood without the context of other words and phrases. For example, *he sunk it* could mean several things, but when the full sentence is included, *He threw the basketball up high from midcourt and sunk it through the hoop for two points*, the meaning is clear. (L4a)

**Root:** The foundation of a word. Knowing the meaning of the root can help a reader determine the meaning of its variations. For example, if you know that a *school* is a place that provides knowledge, you may be able to guess that a *scholar* is someone who is seeking knowledge. (L4b)

### Irony:

- **Verbal Irony:** An expression a person uses that means the opposite of what is said. (L5a)
- **Dramatic Irony:** An event or other literary element of which the reader is aware but that is unknown to the characters. (L5a)
- **Situational Irony:** An instance in which characters' actions have the opposite effect of what is planned. (L5a)

**Pun:** A word or phrase with more than one meaning that is used in a funny way. Here is an example from a fable about fish talking: *The first fish tells the second fish that he can just drop him a line when he is ready to talk*. (L5a)

**Denotation and Connotation:** A connotation is an implied meaning—it is the meaning the writer intends, which may not be the same thing as the literal or dictionary meaning of a word. Denotation is the exact definition of a word. Words can have different connotations depending on how they are used. For example, *polite* and *diplomatic* have similar denotations (respectful, courteous) but can have different connotations (polite is more positive, while diplomatic connotes that the respectful behavior may be masking other true feelings). (L5c)

### Important Tips

- ✍ To study for this part of the EOG assessment, concentrate on the kinds of errors you typically make. Then review grammar rules for those specific kinds of errors. Use books or free online resources to find practice items that you can try. You can work with a partner and question each other on grammar rules or try editing sentences together. Focus your review time on strengthening the areas or skills that need it the most.
- ✍ When you are faced with an unknown word, go back to the passage. Start reading two sentences before the word appears, and continue reading for two sentences afterward or elsewhere in the passage to understand the context in which the word is being used.

## Sample Items 17–20

### Item 17

Which of these is the **BEST** way to revise the underlined sentence so that the paragraph is consistently written in the active voice?

We spent many of our summers on the Georgia Sea Islands. The music played by the residents there was inspiring. I would give anything to play that well.

- A. The music was played by residents, and it was inspiring.
- B. Music was played that was inspired by the residents.
- C. Inspiring music was played by the residents.
- D. The residents played inspiring music.

### Item 18

What is the function of the underlined word in the sentence?

Reading is my favorite way to spend a quiet afternoon.

- A. adjective
- B. noun
- C. preposition
- D. verb

**Item 19**

**Which sentence uses the correct punctuation between clauses?**

- A. I went to the store . . . and I bought paper.
- B. I went to the store—and I bought paper.
- C. I went to the store; and I bought paper.
- D. I went to the store, and I bought paper.

**Item 20**

**Which underlined word contains a spelling error?**

His facial reaction was quite quizical in nature.

- A. facial
- B. reaction
- C. quizical
- D. nature

## ENGLISH LANGUAGE ARTS (ELA) ADDITIONAL SAMPLE ITEM KEYS

Item	Standard/ Element/ Genre	DOK Level	Correct Answer	Explanation
1	ELAGSE8RL3 Literary	2	C	The correct answer is choice (C) He fidgeted with his hat, not knowing where it should go, but certain that it couldn't go back on his head. This shows he is self-conscious. Choice (A) is incorrect. It describes the setting only. Choice (B) is incorrect as it illustrates respect but not being self-conscious. Choice (D) is incorrect as it does not relate to being self-conscious.
2	ELAGSE8RL4 Literary	2	B	The correct answer is choice (B) Caleb was less likely to embarrass himself while he was busy eating. This explains the connotation of <i>merciful</i> . Choice (A) is incorrect because this is not supported in the text. Choice (C) is incorrect because, even though delivering some meals might be an act of mercy, this meal is not charity. Choice (D) is incorrect because the meal was paid for by Bollinger.
3	ELAGSE8RL2 Literary	2	B	The correct answer is choice (B) He should report conditions on the trail. This shows his responsibilities as a Pony Express Rider, so it would belong in a summary. Choices (A), (C), and (D) are incorrect because they are not as important to the passage and would not need to go into a summary. They are details from the passage and not main ideas.
4	ELAGSE8W3	3	N/A	See scoring rubric beginning on page 64 and sample response on page 57.
5	ELAGSE8RI1 Informational/ Explanatory	2	B	The correct answer is choice (B) These odd creatures are not only alive, but living in this dark underworld away from light. This supports the conclusion that this is important. Choices (A), (C), and (D) are incorrect because they are details from the text but do not support this conclusion.
6	ELAGSE8RI4 Informational/ Explanatory	2	C	The correct answer is choice (C) extracting. The passage contrasts the way these life forms obtain, or get, energy to the way most life forms get energy. The creatures are extracting energy to stay alive. Choices (A), (B), and (D) are incorrect because <i>depositing</i> , <i>emptying</i> , and <i>wasting</i> would change the meaning of the sentence.

Item	Standard/ Element/ Genre	DOK Level	Correct Answer	Explanation
7	ELAGSE8RI5 Informational/ Explanatory	3	N/A	See scoring rubric and sample responses on page 58.
8	ELAGSE8RI2 Informational/ Explanatory	3	N/A	See scoring rubric and sample responses on page 59.
9	ELAGSE8L4a	2	C	The correct answer is choice (C) hungrily eat. Pandas pull bamboo off the trees and eat all day. Choice (A) is incorrect because it refers to grabbing onto the bamboo from the trees but not actually eating it. Ingesting is the act of eating. Choice (B) is incorrect because that is not the meaning of <i>ingest</i> . They are not ruining the bamboo, they are eating it. Choice (D) is incorrect because the pandas eat with more intensity than a nibble.
10	ELAGSE8RI Informational/ Explanatory	2	D	The correct answer is choice (D) Ecotourism helps pandas and the national economy. This is the central idea. Choices (A) and (B) are incorrect because these are supporting details and not the central idea. Choice (C) is incorrect because this is not an accurate description of the central idea, though travel is implied.
11	ELAGSE8W2a	3	N/A	See scoring rubric and sample responses on page 60.
12	ELAGSE8RI3 Informational/ Explanatory	3	N/A	See scoring rubric and sample responses on page 61.
13	ELAGSE8W1b	3	C	The correct answer is choice (C) Customers can then decide to use or ignore the information. Choice (A) is incorrect because it does not support the writer's argument. Choice (B) is incorrect and not related to the argument. Choice (D) is incorrect because it is not supported by information in the passage.
14	ELAGSE8W1a	2	D	The correct answer is choice (D) Food should look good and taste good. Choices (A), (B), and (C) are incorrect because they are relevant to the sentences.

Item	Standard/ Element/ Genre	DOK Level	Correct Answer	Explanation
15	ELAGSE8W2e	2	B	The correct answer is choice (B) In fact, the tastiest foods may be the ones with the most calories. This has a more formal style. Choice (A) is incorrect because “Just go for it” is an informal expression. Choice (C) is incorrect, though this is a close answer, but it is not really as formal a choice (B). Choice (D) is incorrect because “No worries” is very informal.
16	ELAGSE8W1	4	N/A	See scoring rubric beginning on page 68 and sample response on page 62.
17	ELAGSE8L1b	2	D	The correct answer is choice (D) The residents played inspiring music. <i>Played</i> is an active verb. Choices (A), (B), and (C) are all in the passive voice.
18	ELAGSE8L1a	2	B	The correct answer is choice (B) noun. The word <i>reading</i> is a gerund and functions as a noun in this sentence. Choices (A) and (C) are incorrect because the word does not function as either of those parts of speech. Choice (D) is incorrect, though it does end in <i>-ing</i> like some verbs. In this case, <i>reading</i> is a noun that is made from a verb.
19	ELAGSE8L2a	1	D	The correct answer is choice (D) I went to the store, and I bought paper. Choice (A) is incorrect because an ellipsis takes the place of text that is omitted. Choice (B) is incorrect because this is an inappropriate use of the dash. Choice (C) is incorrect because the semicolon is inappropriate.
20	ELAGSE8L2c	1	C	The correct answer is choice (C) quizical. <i>Quizzical</i> is one of those troublesome words with a double consonant. Choices (A), (B), and (D) are all spelled correctly.



## ENGLISH LANGUAGE ARTS (ELA) SAMPLE SCORING RUBRICS AND EXEMPLAR RESPONSES

### Item 4

To view the four-point rubric for a text-based narrative response, see pages 64 and 65.

#### Exemplar Response

Points Awarded	Sample Response
4	Well, I got the job and I didn't make too much of a fool of myself. I think Mr. Bollinger knows about my family's business but he didn't even bring it up. He seems to have high hopes for this mail delivery plan, and he's expressed confidence in me. That means that when I make it, I'll make it on my own. It doesn't look easy, however. I'll be riding all day in all kinds of conditions—storms, rock slides, even the chance I'll be stopped by roadside bandits. It seems like the only thing that really rates is the horse. He only works one-sixth of the day, while I work six-sixths of it. But in a way that makes perfect sense. In any rate, I got the job I wanted. I'm going to succeed. I'll make Bollinger and my family back in West Virginia proud.
3	I don't suppose I'll get good treatment like that every day that I work for the Pony Express, but it sure was a good way to begin. Mr. Bollinger seemed like a good man, and he explained the job very clearly. It's a big responsibility, delivering people's mail. But I can do it. This is why I came out here to work on my own. It also looks like an interesting job. There had better be more going on than herding cattle.
2	Boy, they had everything set up for me. Mr. Bollinger ordered my breakfast. They had the mail pouch ready and my first horse all saddled up. This should be a good group to work for.
1	Twelve hours is a long day, but I can do it. Mr. Bollinger has confidence that I can do it, so I can.
0	I am riding the pony.

**Item 7**

**Scoring Rubric**

Points	Description
2	The response achieves the following: <ul style="list-style-type: none"> <li>• Gives sufficient evidence of the ability to analyze the role of specific paragraphs within the text</li> <li>• Includes specific examples/details that make clear reference to the text</li> <li>• Adequately supports examples with clearly relevant information from the text</li> </ul>
1	The response achieves the following: <ul style="list-style-type: none"> <li>• Gives limited evidence of the ability to analyze the role of specific paragraphs within the text</li> <li>• Includes limited examples that make reference to the text</li> <li>• Explains examples with vague/limited information from the text</li> </ul>
0	The response achieves the following: <ul style="list-style-type: none"> <li>• Gives no evidence of the ability to analyze the role of specific paragraphs within the text</li> </ul>

**Exemplar Response**

Points Awarded	Sample Response
2	At first, the description seems to be of some science fiction world. It sounds strange and exotic. Then we find out that it is the bottom of the ocean that is being described. From the start you know that this is unusual. The purpose of the first paragraph is to make you realize that what is happening with the vents is quite different from what was expected.
1	The first paragraph sounds like a movie or a science fiction story. There are creatures that look like worms, but they have red-and-white stripes. This makes the passage really interesting. And scary.
0	There are giant worms. It's a good beginning.

## Item 8

## Scoring Rubric

Points	Description
2	<p>The response achieves the following:</p> <ul style="list-style-type: none"> <li>• Gives sufficient evidence of the ability to determine the central idea of a text and analyze its development over the course of the text</li> <li>• Includes specific examples/details that make clear reference to the text</li> <li>• Adequately supports examples with clearly relevant information from the text</li> </ul>
1	<p>The response achieves the following:</p> <ul style="list-style-type: none"> <li>• Gives limited evidence of the ability to determine the central idea of a text and analyze its development over the course of the text</li> <li>• Includes limited examples/details that make reference to the text</li> <li>• Explains examples with vague/limited information from the text</li> </ul>
0	<p>The response achieves the following:</p> <ul style="list-style-type: none"> <li>• Gives no evidence of the ability to determine the central idea of a text and analyze its development over the course of the text</li> </ul>

## Exemplar Response

Points Awarded	Sample Response
2	<p>The central idea of the passage is that the discovery of the underwater vents has prompted scientists to reconsider the belief that all living organisms need light to survive. The vents are remarkable because they house colonies of living organisms, despite the fact that they represent an environment too hostile to support life as we know it. The organisms living in these vents exist without sunlight. This shocked scientists. This also means that other organisms may be able to exist under these conditions as well.</p>
1	<p>The vents are at the bottom of the ocean, so the organisms that live there get absolutely no sunlight. They are the only life forms known to exist in the total absence of sunlight. Maybe there's life we don't know about in other places.</p>
0	<p>There are strange things living in the sea. Scientists know about them.</p>

**Item 11**

**Scoring Rubric**

Points	Description
2	<p>The exemplar shows a full-credit response. It achieves the following:</p> <ul style="list-style-type: none"> <li>• Gives sufficient evidence of the ability to analyze the structure of the text and how it contributes to the development of ideas</li> <li>• Includes specific examples/details that make clear reference to the text</li> <li>• Adequately supports examples with clearly relevant information from the text</li> </ul>
1	<p>The exemplar shows a 1-point response. It achieves the following:</p> <ul style="list-style-type: none"> <li>• Gives limited evidence of the ability to analyze the structure of the text and how it contributes to the development of ideas</li> <li>• Includes vague/limited examples/details that make reference to the text</li> <li>• Supports examples with clearly relevant information from the text</li> </ul>
0	<p>The exemplar shows a response that would earn no credit. It achieves the following:</p> <ul style="list-style-type: none"> <li>• Gives no evidence of the ability to analyze the structure of the text and how it contributes to the development of ideas</li> </ul>

**Exemplar Response**

Points Awarded	Sample Response
2	<p>The new heading belongs in front of the last paragraph because that one talks about the risks that come with ecotourism. Ecotourism can help because of the revenues and the awareness. However, more people in an environment can endanger it.</p>
1	<p>It should go before paragraph 5. The word <i>risk</i> is used in paragraph 5 and that shows the other side.</p>
0	<p>The author uses two headings.</p>

## Item 12

## Scoring Rubric

Points	Description
2	<p>The exemplar shows a full-credit response. It achieves the following:</p> <ul style="list-style-type: none"> <li>• Gives sufficient evidence of how facts and details develop the topic and ideas in a text</li> <li>• Includes specific examples/details that make clear reference to the text</li> <li>• Adequately supports examples with clearly relevant information from the text</li> </ul>
1	<p>The exemplar shows a 1-point response. It achieves the following:</p> <ul style="list-style-type: none"> <li>• Gives limited evidence of how facts and details develop the topic and ideas in a text</li> <li>• Includes vague/limited examples/details that make reference to the text</li> <li>• Supports examples with clearly relevant information from the text</li> </ul>
0	<p>The exemplar shows a response that would earn no credit. It achieves the following:</p> <ul style="list-style-type: none"> <li>• Gives no evidence of how facts and details develop the topic and ideas in a text</li> </ul>

## Exemplar Response

Points Awarded	Sample Response
2	The first section talks about pandas and how they are becoming extinct. Then in the second section, the author talks about one way to help save and protect pandas through a program called ecotourism. This is like a problem and a solution. You can help save the pandas by visiting them in their own habitat. And the money you spend for your tour is used to take care of the animal and its habitat.
1	The two sections fit together. The first one tells you that the panda is becoming extinct. The second section tells you one way to help save the panda.
0	Both sections are about pandas.

## Item 16

**The following is an example of a seven-point response. See the seven-point, two-trait rubric for a text-based argumentative response on pages 68 and 69 to see why this example would earn the maximum number of points.**

**Example of a Seven-Point Response:**

*I like being informed. I like to know what will be on a test: not the exact questions, but the material. I watch movie trailers to decide if I'll see a particular movie. And I want to know the nutritional information of the food that I put in my body. Knowing the contents of foods alerts me to ingredients that trigger allergies. In addition, knowing the nutrients and calories helps me balance each meal. Fats, sugars, and carbohydrates are part of many foods, but they can be overdone.*

*Labeling is not hard for the majority of restaurants because most of them are chains. They already operate in regions with labeling laws, so they already know the contents of each meal. If their hamburger has 560 calories in New York City, it will have 560 calories here. The restaurants unique to our community are small in number and also small in scope. They specialize in seafood or Thai cuisine. The similarity of offerings will make labeling nearly automatic. Whether difficult or easy, presenting the nutritional information of food is critical to the health of the consumer.*

*I do have some sympathy for the government argument and also for the fact that fewer than half of consumers will probably care. There was a time when the government required manufacturers to put seat belts in cars, and later air bags and anti-lock brakes. At first people resisted wearing the belts and complained about the increased cost. Yet, who would buy a car without those features today? The same will be true for labeling. People will eventually come to realize that they are better off knowing this information to be active participants in promoting their own health.*

*In the meantime, people can pay attention or not. It is their choice. My choice will be to read the contents and eat healthy.*

---

## ENGLISH LANGUAGE ARTS (ELA) WRITING RUBRICS

Grade 8 items that are not machine-scored—i.e., constructed-response, extended constructed-response, and extended writing response items—are manually scored using either a holistic rubric or a two-trait rubric.

### Four-Point Holistic Rubric

#### Genre: Narrative

A holistic rubric evaluates one major feature, which is ideas. On the Georgia Milestones EOG assessment, a holistic rubric is scored from zero to four. Each point value represents the difference in the levels or quality of the student’s work. To score an item on a holistic rubric, the scorer need only choose the description and associated point value that best represents the student’s work. Increasing point values represent a greater understanding of the content and, thus, a higher score.

### Seven-Point, Two-Trait Rubric

#### Genre: Argumentative or Informational/Explanatory

A two-trait rubric, on the other hand, evaluates two major traits, which are conventions and ideas. On the Georgia Milestones EOG assessment, a two-trait rubric contains two scales, one for each trait, ranging from zero to three on one scale (conventions) and zero to four on the other (ideas). A score is given for each of the two traits, for a total of seven possible points for the item. To score an item on a two-trait rubric, a scorer must choose the description and associated point value for each trait that best represents the student’s work. The two scores are added together. Increasing point values represent a greater understanding of the content and, thus, a higher score.

On the following pages are the rubrics that will be used to evaluate writing on the Georgia Milestones Grade 8 English Language Arts EOG assessment.

### Four-Point Holistic Rubric

#### Genre: Narrative

Writing Trait	Points	Criteria
<p><i>This trait examines the writer's ability to effectively develop real or imagined experiences or events using effective techniques, descriptive details, and clear event sequences based on a text that has been read.</i></p>	4	<p><i>The student's response is a well-developed narrative that fully develops a real or imagined experience based on text as a stimulus.</i></p> <ul style="list-style-type: none"> <li>• Effectively establishes a situation and a point of view and introduces a narrator and/or characters</li> <li>• Organizes an event sequence that unfolds naturally and logically</li> <li>• Effectively uses narrative techniques, such as dialogue, description, pacing, and reflection, to develop rich, interesting experiences, events, and/or characters</li> <li>• Uses a variety of words and phrases consistently and effectively to convey the sequence of events, signal shifts from one time frame or setting to another, and show the relationships among experiences and events</li> <li>• Uses precise words, phrases, and sensory language to convey experiences and events and capture the action</li> <li>• Provides a conclusion that follows from the narrated experiences or events</li> <li>• Integrates ideas and details from source material effectively</li> <li>• Has very few or no errors in usage and/or conventions that interfere with meaning*</li> </ul>
	3	<p><i>The student's response is a complete narrative that develops a real or imagined experience based on text as a stimulus.</i></p> <ul style="list-style-type: none"> <li>• Establishes a situation and introduces one or more characters</li> <li>• Organizes events in a clear, logical order</li> <li>• Uses narrative techniques, such as dialogue, description, pacing, and reflection, to develop experiences, events, and/or characters</li> <li>• Uses words and/or phrases to indicate sequence, signal shifts from one time frame or setting to another, and show the relationships among experiences and events</li> <li>• Uses words, phrases, and details to capture the action and convey experiences and events</li> <li>• Provides an appropriate conclusion</li> <li>• Integrates some ideas and/or details from source material</li> <li>• Has a few minor errors in usage and/or conventions that interfere with meaning*</li> </ul>



## Four-Point Holistic Rubric

### Genre: Narrative (continued)

Writing Trait	Points	Criteria
<p><i>This trait examines the writer's ability to effectively develop real or imagined experiences or events using effective techniques, descriptive details, and clear event sequences based on a text that has been read.</i></p>	2	<p><i>The student's response is an incomplete or oversimplified narrative based on text as a stimulus.</i></p> <ul style="list-style-type: none"> <li>• Introduces a vague situation and at least one character</li> <li>• Organizes events in a sequence but with some gaps or ambiguity</li> <li>• Attempts to use a narrative technique, such as dialogue, description, pacing, or reflection, to develop experiences, events, and/or characters</li> <li>• Uses occasional signal words inconsistently and ineffectively to indicate sequence, signal shifts from one time frame or setting to another, or show the relationships among experiences and events</li> <li>• Uses some words or phrases inconsistently and ineffectively to convey experiences, and events, and capture the action</li> <li>• Provides a weak or ambiguous conclusion</li> <li>• Attempts to integrate ideas or details from source material</li> <li>• Has frequent errors in usage and conventions that sometimes interfere with meaning*</li> </ul>
	1	<p><i>The student's response provides evidence of an attempt to write a narrative based on text as a stimulus.</i></p> <ul style="list-style-type: none"> <li>• Response is a summary of the story.</li> <li>• Provides a weak or minimal introduction of a situation or character</li> <li>• May be too brief to demonstrate a complete sequence of events, or signal shifts in one time frame or setting to another, or show relationships among experiences and events</li> <li>• Shows little or no attempt to use dialogue, description, pacing, or reflection to develop experiences, events, and/or characters</li> <li>• Uses words that are inappropriate, overly simple, or unclear</li> <li>• Provides few, if any, words to convey experiences, or events, or capture the action</li> <li>• Provides a minimal or no conclusion</li> <li>• May use few, if any, ideas or details from source material</li> <li>• Has frequent major errors in usage and conventions that interfere with meaning*</li> </ul>
	0	<p><i>The student's response is flawed for various reasons and will receive a condition code:</i></p> <ul style="list-style-type: none"> <li>• Code A: Blank</li> <li>• Code B: Copied</li> <li>• Code C: Too Limited to Score/Illegible/Incomprehensible</li> <li>• Code D: Non-English/Foreign Language</li> <li>• Code E: Off Topic/Off Task/Offensive</li> </ul>

\*Students are responsible for language conventions learned in their current grade as well as in prior grades. Refer to the language skills for each grade to determine the grade-level expectations for grammar, syntax, capitalization, punctuation, and spelling. Also refer to the "Language Progressive Skills, by Grade" chart in Appendix A for those standards that need continued attention beyond the grade in which they were introduced.

## Seven-Point, Two-Trait Rubric

### Trait 1 for Informational/Explanatory Genre

Writing Trait	Points	Criteria
<p><b>Idea Development, Organization, and Coherence</b></p> <p><i>This trait examines the writer's ability to effectively establish a controlling idea and to support the idea with evidence from the text(s) read and to elaborate on the idea with examples, illustrations, facts, and other details in order. The writer must integrate the information from the text(s) into his/her own words and arrange the ideas and supporting evidence (from text that they have read) in order to create cohesion for an informative/explanatory essay.</i></p>	4	<p><i>The student's response is a well-developed informative/explanatory text that examines a topic in depth and conveys ideas and information clearly based on text as a stimulus.</i></p> <ul style="list-style-type: none"> <li>• Effectively introduces a topic</li> <li>• Effectively organizes ideas, concepts, and information using various strategies such as definition, classification, comparison/contrast, and cause/effect</li> <li>• Effectively develops the topic with multiple, relevant facts, definitions, concrete details, quotations, or other information and examples related to the topic</li> <li>• Effectively uses appropriate and varied transitions to create cohesion and clarify the relationships among ideas and concepts</li> <li>• Uses precise language and domain-specific vocabulary to inform about or explain the topic</li> <li>• Establishes and maintains a formal style</li> <li>• Provides a strong concluding statement or section that follows from and supports the information or explanation presented</li> </ul>
	3	<p><i>The student's response is a complete informative/explanatory text that examines a topic and presents information based on a text as a stimulus.</i></p> <ul style="list-style-type: none"> <li>• Introduces a topic</li> <li>• Generally organizes ideas, concepts, and information</li> <li>• Develops the topic with a few facts, definitions, concrete details, quotations, or other information and examples</li> <li>• Uses some transitions to connect and clarify relationships among ideas, but relationships may not always be clear</li> <li>• Uses some precise language and domain-specific vocabulary to explain the topic</li> <li>• Maintains a formal style, for the most part</li> <li>• Provides a concluding statement or section</li> </ul>
	2	<p><i>The student's response is an incomplete or oversimplified informative/explanatory text that cursorily examines a topic.</i></p> <ul style="list-style-type: none"> <li>• Attempts to introduce a topic</li> <li>• Attempts to develop a topic with too few details</li> <li>• Ineffectively organizes ideas, concepts, and information</li> <li>• Uses limited language and vocabulary that does not inform or explain the topic</li> <li>• Uses few transitions to connect and clarify relationships among ideas</li> <li>• Uses a formal style inconsistently or uses an informal style</li> <li>• Provides a weak concluding statement or section</li> </ul>
	1	<p><i>The student's response is a weak attempt to write an informative/explanatory text that examines a topic.</i></p> <ul style="list-style-type: none"> <li>• May not introduce a topic or topic is unclear</li> <li>• May not develop a topic</li> <li>• May be too brief to group any related ideas together</li> <li>• May not use any linking words to connect ideas</li> <li>• Uses vague, ambiguous, or repetitive language</li> <li>• Uses a very informal style</li> <li>• Provides a minimal or no concluding statement or section</li> </ul>
	0	<p><i>The student's response is flawed for various reasons and will receive a condition code:</i></p> <ul style="list-style-type: none"> <li>• Code A: Blank</li> <li>• Code B: Copied</li> <li>• Code C: Too Limited to Score/Illegible/Incomprehensible</li> <li>• Code D: Non-English/Foreign Language</li> <li>• Code E: Off Topic/Off Task/Offensive</li> </ul>

## Seven-Point, Two-Trait Rubric

### Trait 2 for Informational/Explanatory Genre

Writing Trait	Points	Criteria
<b>Language Usage and Conventions</b> <i>This trait examines the writer's ability to demonstrate control of sentence formation, usage, and mechanics as embodied in the grade-level expectations of the language standards.</i>	3	<i>The student's response demonstrates full command of language usage and conventions.</i> <ul style="list-style-type: none"> <li>• Effectively varies sentence patterns for meaning, reader/listener interest, and style</li> <li>• Shows command of language and conventions when writing</li> <li>• Any errors in usage and conventions do not interfere with meaning*</li> </ul>
	2	<i>The student's response demonstrates partial command of language usage and conventions.</i> <ul style="list-style-type: none"> <li>• Varies some sentence patterns for meaning, reader/listener interest, and style</li> <li>• Shows some knowledge of languages and conventions when writing</li> <li>• Has minor errors in usage and conventions with no significant effect on meaning*</li> </ul>
	1	<i>The student's response demonstrates weak command of language usage and conventions.</i> <ul style="list-style-type: none"> <li>• Has fragments, run-ons, and/or other sentence structure errors</li> <li>• Shows little knowledge of languages and conventions when writing</li> <li>• Has frequent errors in usage and conventions that interfere with meaning*</li> </ul>
	0	<i>The student's response is flawed for various reasons and will receive a condition code:</i> <ul style="list-style-type: none"> <li>• Code A: Blank</li> <li>• Code B: Copied</li> <li>• Code C: Too Limited to Score/Illegible/Incomprehensible</li> <li>• Code D: Non-English/Foreign Language</li> <li>• Code E: Off Topic/Off Task/Offensive</li> </ul>

\*Students are responsible for language conventions learned in their current grade as well as in prior grades. Refer to the language skills for each grade to determine the grade-level expectations for grammar, syntax, capitalization, punctuation, and spelling. Also refer to the "Language Progressive Skills, by Grade" chart in Appendix A for those standards that need continued attention beyond the grade in which they were introduced.

## Seven-Point, Two-Trait Rubric

### Trait 1 for Argumentative Genre

Writing Trait	Points	Criteria
<p><b>Idea Development, Organization, and Coherence</b></p> <p><i>This trait examines the writer's ability to effectively establish a claim as well as to address counterclaims, to support the claim with evidence from the text(s) read, and to elaborate on the claim with examples, illustrations, facts, and other details. The writer must integrate the information from the text(s) into his/her own words and arrange the ideas and supporting evidence in order to create cohesion for an argument essay.</i></p>	4	<p><i>The student's response is a well-developed argument that effectively relates and supports claims with clear reasons and relevant text-based evidence.</i></p> <ul style="list-style-type: none"> <li>• Effectively introduces claim(s)</li> <li>• Uses an organizational strategy to present reasons and relevant evidence logically</li> <li>• Supports claim(s) with clear reasons and relevant evidence using specific, well-chosen facts, details, or other information from credible sources and demonstrates a good understanding of the topic or texts</li> <li>• Acknowledges and counters opposing claim(s), as appropriate</li> <li>• Uses words, phrases, and/or clauses that effectively connect and show direct, strong relationships among claim(s), reasons, and evidence</li> <li>• Establishes and maintains a formal style that is appropriate for the task, purpose, and audience</li> <li>• Provides a strong concluding statement or section that logically follows from the argument presented</li> </ul>
	3	<p><i>The student's response is a complete argument that relates and supports claims with some text-based evidence.</i></p> <ul style="list-style-type: none"> <li>• Clearly introduces claim(s)</li> <li>• Uses an organizational strategy to present some reasons and evidence</li> <li>• Uses specific facts, details, definitions, examples, and/or other information from sources to develop claim(s)</li> <li>• Attempts to acknowledge and/or counter opposing claim(s), as appropriate</li> <li>• Uses words and/or phrases to connect ideas and show relationships among claim(s), reasons, and evidence</li> <li>• Uses a formal style fairly consistently for task, purpose, and audience</li> <li>• Provides a concluding statement or section that follows from the argument presented</li> </ul>
	2	<p><i>The student's response is an incomplete or oversimplified argument that partially supports claims with loosely related, text-based evidence.</i></p> <ul style="list-style-type: none"> <li>• Attempts to introduce claim(s)</li> <li>• Attempts to use an organizational structure which may be formulaic</li> <li>• Develops, sometimes unevenly, reasons and/or evidence to support claim(s)</li> <li>• Makes little, if any, attempt to acknowledge or counter opposing claim(s)</li> <li>• Attempts to support claim(s) with facts, reasons, and other evidence sometimes, but logic and relevancy are often unclear</li> <li>• Uses few words or phrases to connect ideas; connections are not always clear</li> <li>• Uses a formal style inconsistently or an informal style that does not fit task, purpose, or audience</li> <li>• Provides a weak concluding statement or section that may not follow the argument presented</li> </ul>
	1	<p><i>The student's response is a weak attempt to write an argument and does not support claims with adequate text-based evidence.</i></p> <ul style="list-style-type: none"> <li>• May not introduce claim(s)/claims(s) must be inferred</li> <li>• May be too brief to demonstrate an organizational structure, or no structure is evident</li> <li>• Has minimal support for claim(s)</li> <li>• Makes no attempt to acknowledge or counter opposing claim(s)</li> <li>• Uses minimal or no words or phrases to connect ideas</li> <li>• Uses a very informal style that is not appropriate for task, purpose, or audience</li> <li>• Provides a minimal or no concluding statement or section</li> </ul>
	0	<p><i>The student's response is flawed for various reasons and will receive a condition code:</i></p> <ul style="list-style-type: none"> <li>• Code A: Blank</li> <li>• Code B: Copied</li> <li>• Code C: Too Limited to Score/Illegible/Incomprehensible</li> <li>• Code D: Non-English/Foreign Language</li> <li>• Code E: Off Topic/Off Task/Offensive</li> </ul>

## Seven-Point, Two-Trait Rubric

### Trait 2 for Argumentative Genre

Writing Trait	Points	Criteria
<p><b>Language Usage and Conventions</b></p> <p><i>This trait examines the writer's ability to demonstrate control of sentence formation, usage, and mechanics as embodied in the grade-level expectations of the language standards.</i></p>	3	<p><i>The student's response demonstrates full command of language usage and conventions.</i></p> <ul style="list-style-type: none"> <li>• Effectively varies sentence patterns for meaning, reader/listener interest, and style</li> <li>• Shows command of language and conventions when writing</li> <li>• Any errors in usage and conventions do not interfere with meaning*</li> </ul>
	2	<p><i>The student's response demonstrates partial command of language usage and conventions.</i></p> <ul style="list-style-type: none"> <li>• Varies some sentence patterns for meaning, reader/listener interest, and style</li> <li>• Shows some knowledge of languages and conventions when writing</li> <li>• Has minor errors in usage and conventions with no significant effect on meaning*</li> </ul>
	1	<p><i>The student's response demonstrates weak command of language usage and conventions.</i></p> <ul style="list-style-type: none"> <li>• Has fragments, run-ons, and/or other sentence structure errors</li> <li>• Shows little knowledge of languages and conventions when writing</li> <li>• Has frequent errors in usage and conventions that interfere with meaning*</li> </ul>
	0	<p><i>The student's response is flawed for various reasons and will receive a condition code:</i></p> <ul style="list-style-type: none"> <li>• Code A: Blank</li> <li>• Code B: Copied</li> <li>• Code C: Too Limited to Score/Illegible/Incomprehensible</li> <li>• Code D: Non-English/Foreign Language</li> <li>• Code E: Off Topic/Off Task/Offensive</li> </ul>

\*Students are responsible for language conventions learned in their current grade as well as in prior grades. Refer to the language skills for each grade to determine the grade-level expectations for grammar, syntax, capitalization, punctuation, and spelling. Also refer to the "Language Progressive Skills, by Grade" chart in Appendix A for those standards that need continued attention beyond the grade in which they were introduced.

## ACTIVITY

**The following activity develops skills in Unit 1: Reading Literary Text.**

**Standards:** ELAGSE8.RL.1, ELAGSE8.RL.2, ELAGSE8.RL.3, ELAGSE8.RL.4, ELAGSE8.RL.5, ELAGSE8.RL.6, and ELAGSE8.RL.9

### ***The Daily Reporter***

Get your pad, pen, and press badge and join the staff of *The Daily Reporter* news team! You can do the following activity with friends or on your own.

### **Interview with a Friend or Family Member**

You will need a reporter and a character from a story, novel, or play to interview.

- Choose a character you have read about and answer all questions as that character.
- The reporter should ask questions that pertain to events that took place in the story, novel, or play that the character comes from.
- You can also ask questions that require the character to reveal thoughts, feelings, and reactions to events and other characters.
- Think about what the character is like and what caused specific events to take place.
- The character may be asked to make a judgment or draw a conclusion about people and events from the text.
- The reporter will ask the character questions and record the responses.

Example: You have just read *To Kill a Mockingbird* by Harper Lee. The reporter can interview Atticus Finch and ask him how he felt about the trial or its outcome, or you may choose to interview Scout and get her reaction to how the trial affected her father or what she thinks about growing up in Maycomb, Alabama.

After the interview, the questions and answers can be presented in several ways.

- Write a newspaper report. If you have access to a computer, you can design a page that looks like the front page of a newspaper.
- Write the interview as a dialogue between the reporter and the character.
- Present this as a live interview on a TV news show. You can set up two chairs at the front of the class and interview the character using the questions and answers as the script.

### **On Your Own**

You can do this activity on your own after reading a story, novel, or play. Choose a character who interests you and write the questions and answers yourself. Prepare the questions and answers as either a newspaper report or a dialogue.

---

## ACTIVITY

The following activity develops skills in Unit 5: Language.

**Standards:** ELAGSE8.L.4 and ELAGSE8.L.5

### Word Match Game

You can play this game by yourself, with a friend, or with your family.

Create a list of vocabulary words. These words can come from your reading, spelling lists, or the glossaries of science, math, or social studies textbooks.

Write each word on an index card. If you do not have blank cards, take a sheet of paper and fold it in half. Then fold it in half a second time so that there are four rectangles. Cut these rectangles apart.

- Write a word on each card or piece of paper.
- On a different index card or piece of paper, write a synonym or definition of the word.

Start with eight words and their matching definitions.

- Mix them up and put the cards face up on the table in four rows of four cards each.

Find a word and its matching definition and turn it over.

- You can do this yourself, take turns with a friend or family member, or let each person see if he or she can match the eight words on his or her own.

Keep playing with the next set of eight words.

Play this game just for fun or to review words before a test or quiz.

- You can also use it as a way to study with a friend and test each other on how well you know the definitions of each word.

As an alternate way of playing, get a timer. Set the timer for a minute or use an hourglass timer that is filled with sand and turn it over.

- When time is up, count how many words were correctly matched.
- Award two points for each match.
- The player with the most points at the end of the game wins.

# MATHEMATICS

## DESCRIPTION OF TEST FORMAT AND ORGANIZATION

The Grade 8 Mathematics EOG assessment consists of a total of 73 items.

You will answer a variety of item types on the test. Some of the items are selected response (multiple-choice), which means you choose the correct answer from four choices. Some items will ask you to write your response.

The test will be given in two sections.

- You may have up to 85 minutes per section to complete Sections 1 and 2.
- The test will take about 120 to 170 minutes.

## CONTENT

The Grade 8 Mathematics EOG assessment will measure the Grade 8 standards that are described at [www.georgiastandards.org](http://www.georgiastandards.org).

The content of the assessment covers standards that are reported under these domains:

- Numbers, Expressions, and Equations
- Algebra and Functions
- Geometry
- Statistics and Probability

## ITEM TYPES

The Mathematics portion of the Grade 8 EOG assessment consists of selected-response (multiple-choice) items, constructed-response items, and extended constructed-response items.



## MATHEMATICS DEPTH OF KNOWLEDGE EXAMPLE ITEMS

Example items that represent applicable DOK levels of the Mathematics assessment are provided for you on the following pages. The items and explanations of what is expected of you to answer them will help you prepare for the test.

**All example and sample items contained in this guide are the property of the Georgia Department of Education.**

### Example Item 1

**DOK Level 1:** This is a DOK level 1 item because it requires students to recall a square root.

**Mathematics Grade 8 Content Domain II:** Numbers, Expressions, and Equations

**Standard:** MGSE8.NS.2. Use rational approximation of irrational numbers to compare the size of irrational numbers, locate them approximately on a number line, and estimate the value of expressions (e.g., estimate  $\pi^2$  to the nearest tenth). *For example, by truncating the decimal expansion of  $\sqrt{2}$  (square root of 2), show that  $\sqrt{2}$  is between 1 and 2, then between 1.4 and 1.5, and explain how to continue on to get better approximations.*

**Which of these is the closest approximation to the value of  $\sqrt{97}$ ?**

- A. 9
- B. 10
- C. 48
- D. 49

**Correct Answer:** B

**Explanation of Correct Answer:** The correct answer is choice (B) 10. The square root of 97 is between the perfect squares 81 and 100, but it is closer to the square root of 100. Choice (A) is incorrect because the square root of 81 is 9, but the square root of 100 is 10, which the square root of 97 is closer to. Choice (C) is incorrect because it is a result of dividing 97 by 2 and incorrectly rounding down. Choice (D) is incorrect because it is a result of dividing 97 by 2 and rounding up.



### Scoring Rubric

Points	Description
2	<p>The response achieves the following:</p> <ul style="list-style-type: none"> <li>The response demonstrates a complete understanding of constructing functions to model a linear relationship between quantities.</li> <li>Give 2 points for the correct rate of change and identifying the correct equation and rationale. <ul style="list-style-type: none"> <li>Response is correct and complete.</li> <li>Response shows application of a reasonable and relevant strategy.</li> <li>Mathematical ideas are expressed coherently through a clear, complete, logical, and fully developed response using words, calculations, and/or symbols, as appropriate.</li> </ul> </li> </ul>
1	<p>The response achieves the following:</p> <ul style="list-style-type: none"> <li>The response demonstrates a partial understanding of constructing functions to model a linear relationship between quantities.</li> <li>Give 1 point if Part A OR Part B is correct. <ul style="list-style-type: none"> <li>Response is mostly correct, but contains either a computational error or an unclear or incomplete explanation.</li> <li>Response shows application of a relevant strategy, though it may be only partially applied or remain unexplained.</li> </ul> </li> <li>Mathematical ideas are expressed only partially using words, calculations, and/or symbols, as appropriate.</li> </ul>
0	<p>The response achieves the following:</p> <ul style="list-style-type: none"> <li>Response demonstrates limited to no understanding of constructing functions to model a linear relationship between quantities. <ul style="list-style-type: none"> <li>Response is incorrect.</li> <li>Response shows no application of a strategy.</li> </ul> </li> <li>Mathematical ideas cannot be interpreted or lack sufficient evidence to support even a limited understanding.</li> </ul>

### Exemplar Response

Points Awarded	Sample Response
2	<p>Part A: 2</p> <p>Part B: Yes. The equation represents the function because it is a linear function with a slope of 2 and an initial value of 3.</p> <p><i>OR other valid explanation</i></p>
1	<p>Part A: 2</p> <p>Part B: No. The equation does not represent the function because its initial value should be negative.</p>
0	<p><i>Response is irrelevant, inappropriate, or not provided.</i></p>

### Example Item 3

**DOK Level 3:** This is a DOK level 3 item that assesses complex reasoning. Students have to apply their knowledge of decimals and explain their reasoning. It is also an example of an extended constructed-response item.

**Mathematics Grade 8 Content Domain II:** Numbers, Expressions, and Equations

**Standard:** MGSE8.NS.1. Know that numbers that are not rational are called irrational. Understand informally that every number has a decimal expansion; for rational numbers, show that the decimal expansion repeats eventually, and convert a decimal expansion, which repeats eventually into a rational number.

Part A: Is  $0.\overline{571428}$  the decimal equivalent of  $\frac{4}{7}$ ? Explain your reasoning.

_____
_____
_____
_____

Part B: Is the number in Part A rational or irrational? Explain your reasoning.

_____
_____
_____
_____

Part C: What is  $0.\overline{166}$  written as a fraction?

_____
_____
_____
_____

Part D: Is the number in Part C rational or irrational? Explain your reasoning.

_____
_____
_____
_____

### Scoring Rubric

Points	Description
4	<p>The response achieves the following:</p> <ul style="list-style-type: none"> <li>• The response demonstrates a complete understanding of calculating decimal equivalents of fractions and recognizing repeating decimals as rational numbers.</li> <li>• Give 4 points for four parts answered correctly.               <ul style="list-style-type: none"> <li>• Response is correct and complete.</li> <li>• Response shows application of a reasonable and relevant strategy.</li> </ul> </li> <li>• Mathematical ideas are expressed coherently through a clear, complete, logical, and fully developed response using words, calculations and/or symbols, as appropriate.</li> </ul>
3	<p>The response achieves the following:</p> <ul style="list-style-type: none"> <li>• The response demonstrates a nearly complete understanding of calculating decimal equivalents of fractions and recognizing repeating decimals as rational numbers.</li> <li>• Give 3 points for three parts answered correctly or for two parts correct and two parts partially correct.               <ul style="list-style-type: none"> <li>• Response is mostly correct, but contains either a computational error or an unclear or incomplete explanation.</li> <li>• Response shows application of a relevant strategy, though it may be only partially applied or remain unexplained.</li> </ul> </li> <li>• Mathematical ideas are expressed only partially using words, calculations, and/or symbols, as appropriate.</li> </ul>
2	<p>The response achieves the following:</p> <ul style="list-style-type: none"> <li>• The response demonstrates a partial understanding of calculating decimal equivalents of fractions and recognizing repeating decimals as rational numbers.</li> <li>• Give 2 points for two parts answered correctly or for three parts partially correct.               <ul style="list-style-type: none"> <li>• Response is only partially correct.</li> <li>• Response shows application of a relevant strategy, though it may be only partially applied or remain unexplained.</li> </ul> </li> <li>• Mathematical ideas are expressed only partially using words, calculations, and/or symbols, as appropriate.</li> </ul>

Points	Description
1	<p>The response achieves the following:</p> <ul style="list-style-type: none"><li>• The response demonstrates a minimal understanding of calculating decimal equivalents of fractions and recognizing repeating decimals as rational numbers.</li><li>• Give 1 point for one part answered correctly or for two parts partially correct.<ul style="list-style-type: none"><li>• Response is only partially correct.</li><li>• Response shows incomplete or inaccurate application of a relevant strategy.</li></ul></li><li>• Mathematical ideas are expressed only partially using words, calculations, and/or symbols, as appropriate.</li></ul>
0	<p>The response achieves the following:</p> <ul style="list-style-type: none"><li>• The response demonstrates limited to no understanding of calculating decimal equivalents of fractions and recognizing repeating decimals as rational numbers.<ul style="list-style-type: none"><li>• Response is incorrect.</li><li>• Response shows no application of a strategy.</li></ul></li><li>• Mathematical ideas cannot be interpreted or lack sufficient evidence to support even a limited understanding.</li></ul>

**Exemplar Response**

Points Awarded	Sample Response
4	<p>Part A: Yes, it is the correct decimal equivalent of the fraction. I know because I divided the numerator, 4, by the denominator, 7. The quotient was the given repeating decimal.</p> <p>AND</p> <p>Part B: The number is rational because by dividing 7 into 4, you eventually start repeating a pattern that leads to a repeating decimal. Repeating decimals are rational numbers.</p> <p>AND</p> <p>Part C: <math>166/999</math></p> <p>Part D: The number is rational because any number that can be written as a fraction with nonzero integers in the numerator and denominator is a rational number.</p>
3	The student correctly answers three out of the four parts.
2	The student correctly answers two out of the four parts.
1	The student correctly answers one of the four parts.
0	<i>Response is irrelevant, inappropriate, or not provided.</i>



---

## MATHEMATICS CONTENT DESCRIPTION AND ADDITIONAL SAMPLE ITEMS

In this section, you will find information about what to study in order to prepare for the Grade 8 Mathematics EOG assessment. This includes key terms and important vocabulary words. This section also contains practice questions, with an explanation of the correct answers, and activities that you can do on your own or with your classmates or family to prepare for the assessment.

**All example and sample items contained in this guide are the property of the Georgia Department of Education.**

### CONTENT DESCRIPTION

- Apply and extend understanding of rational numbers
- Work with radicals and integer exponents
- Understand congruence and similarity using physical models or software
- Apply the Pythagorean theorem
- Solve real-world and mathematical problems involving volume of cylinders, cones, and spheres
- Understand the connections between proportional relationships, lines, and linear equations
- Analyze and solve linear equations
- Define, evaluate, and compare functions, and use functions to model relationships between quantities
- Investigate patterns of association in bivariate data

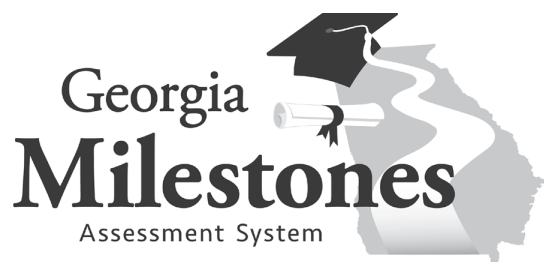

## Mathematics Formula Sheet

---

You can find mathematics formula sheets on the Georgia Milestones webpage at <http://www.gadoe.org/Curriculum-Instruction-and-Assessment/Assessment/Pages/Georgia-Milestones-Assessment-System.aspx>.

**Look under “EOG Resources.”**

## Unit 1: Transformations, Congruence, and Similarity

In this unit, you will work with transformations and identify and compare similar and congruent figures. You will identify and measure angles and study line segments.

### KEY TERMS

**Transformation:** The movement of a figure by performing the same operation or movement on each point of the figure.

- **Rotation:** Turns a figure around a fixed point. Movement is described by an angle of rotation and a direction the figure is turned.
- **Reflection:** Flips a figure over a line of reflection.
- **Translation:** Sliding or moving all points of a figure a specific distance in a given direction.
- **Dilation:** Changing the size of a figure based on a scale factor. The scale factor is applied to the distance from a fixed center to each point of the figure. (G.1)

**Transformations** do not change the shape or relationship between attributes of a figure. A **line segment** will remain a line segment and will not change size unless the figure is dilated. **Angles** will remain the same **degree of measure** in all figures. Also, **parallel lines** will remain parallel. (G.1)

**Congruent figures:** Shapes that have the same size and shape, the result of any combination of rotations, reflections, or translations. (G.2)

An effect of a transformation can be described using the **coordinates** on the **coordinate plane** of the original figure and the transformed figure. (G.3)

**Similar figures:** Shapes that have the same shape but different sizes, the result of any combination of rotations, reflections, translations, and dilations. (G.4)

Describe the **sequence of transformations** that a two-dimensional shape undergoes to result in a **congruent** or **similar** figure. This includes the type of transformation, angle of rotation, reflection line, distance and direction translated, and the factor of dilation. (G.2, G.4)

The measure of an **exterior angle** of a triangle is equal to the sum of the two **opposite interior angles**. The two opposite angles do not share a side or vertex with the exterior angle. (G.5)

A set of **parallel lines** that is cut by a **transversal** results in **alternate angles** that are congruent and same-side angles that are supplementary. (G.5)

**Transversal:** A line crossing two or more lines. (G.5)

**Alternate angles:** A pair of angles formed when a transversal crosses two parallel lines. The angles are on the opposite sides of the transversal and on either the **interior** or the **exterior** of the parallel lines. The angles are equal or congruent. (G.5)

**Same-side angles:** A pair of angles formed when a transversal crosses two parallel lines. The angles are on the same side of the transversal and on either the **interior** or the **exterior** of the parallel lines. The angles are supplementary, or have a sum of  $180^\circ$ . (G.5)

To determine whether two triangles are similar, compare **corresponding sides** or **corresponding angles**. The length of all three pairs of corresponding sides will be proportional. Or, the measures of the angles can be compared and each pair of corresponding angles will be equal.

**Important Tips**

- ✍ Two congruent figures have the same size and shape. Two similar figures have the same shape and angle measures. The length of each corresponding side is proportional to the original figure using a scale factor.
- ✍ A scale factor or factor of dilation that is greater than 1 will increase the size of the shape. A factor of dilation that is less than 1 will decrease the size of the shape.

**Sample Items 1–3**

**Item 1**

Look at the graph of a line segment before and after a transformation occurred.

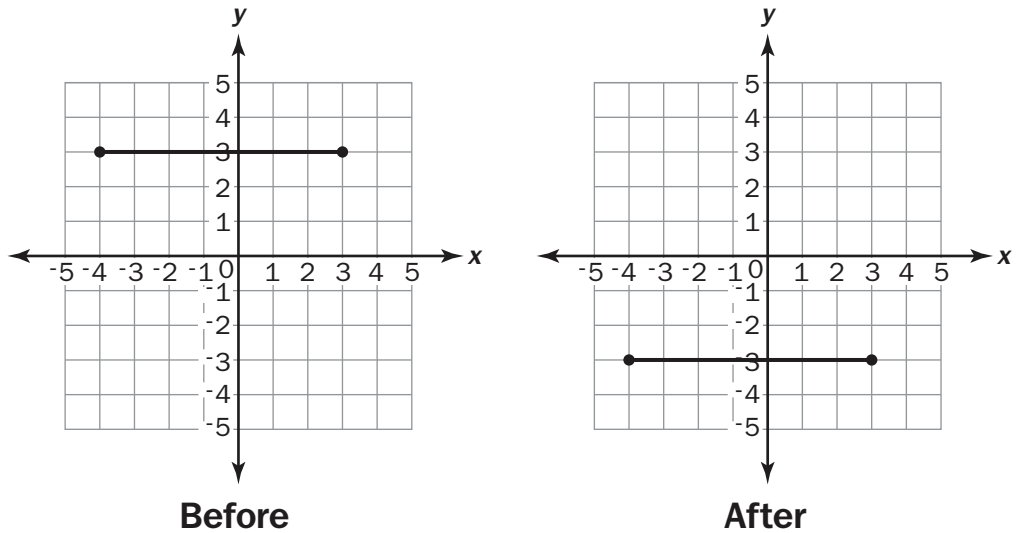

Which statement describes the transformation that could have been made on the line segment?

- A. The line segment was dilated by a factor of  $\frac{1}{2}$ .
- B. The line segment was rotated  $180^\circ$  counterclockwise about the origin.
- C. The line segment was reflected over the x-axis.
- D. The line segment was translated 6 units down and 1 unit left.

**Item 2**

Quadrilaterals  $ABCD$ ,  $A'B'C'D'$ , and  $A''B''C''D''$  are shown on the graph.

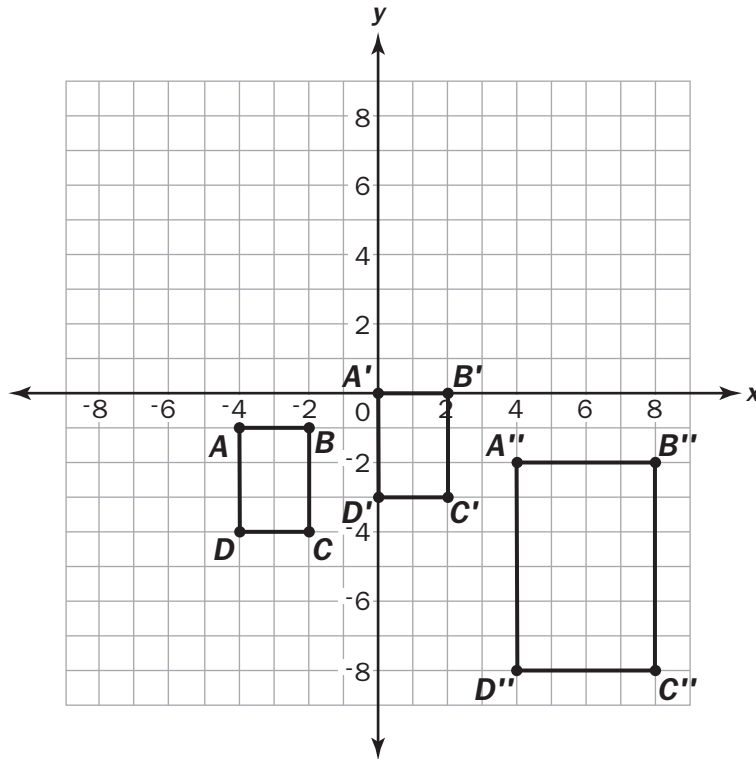

**Part A:** Describe a transformation or sequence of transformations to quadrilateral  $ABCD$  that would result in an image quadrilateral with the coordinates  $A'(0, 0)$ ,  $B'(2, 0)$ ,  $C'(2, -3)$ , and  $D'(0, -3)$ .

---

---

---

---

---

---

---

---

---

---

**Part B:** A sequence of transformations to quadrilateral  $A'B'C'D'$  that would result in an image quadrilateral  $A''B''C''D''$ , as shown in the graph, starts with a dilation about the origin. This is followed by a horizontal and a vertical translation. Name the horizontal and vertical translation.

_____
_____
_____
_____
_____

**Part C:** What is the scale factor of the dilation described in Part B?

_____
_____
_____
_____
_____

**Part D:** Is there another sequence of transformations that could result in the same coordinates? Explain your reasoning.

_____
_____
_____
_____
_____

**Item 3**

A line segment on a graph has endpoints of  $(-3, 1)$  and  $(3, 1)$ . It is translated 5 units down and reflected across the  $x$ -axis.

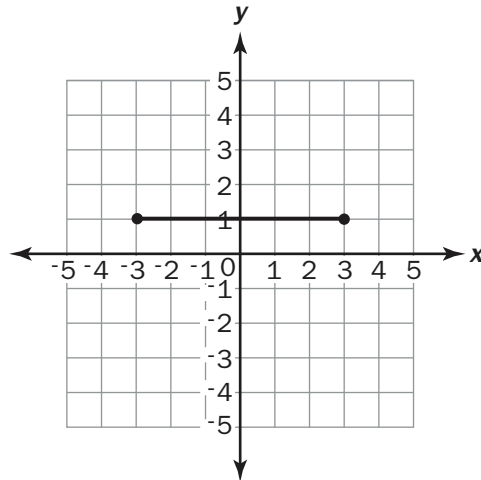

What are the endpoints after the series of transformations?

- A.  $(-3, -4)$  and  $(3, 4)$
- B.  $(-3, -1)$  and  $(3, -1)$
- C.  $(-3, 4)$  and  $(3, 4)$
- D.  $(-3, -6)$  and  $(3, -6)$

## Unit 2: Exponents

In this unit, you will work with exponents, square roots, rational and irrational numbers, and scientific notation.

### KEY TERMS

**Exponent:** Represents repeated multiplication and is one strategy for representing very large or very small numbers. For example,  $10 \cdot 10 \cdot 10 = 10^3$ , so 10 is multiplied by itself 3 times, and the base of 10 is written with an exponent of 3. The same strategy for writing exponents can be used with any number or variable. (EE.1)

**Square root:** One of two equal factors that equals a nonnegative number. For example,  $\sqrt{9} = 3$  because  $3^2 = 3 \cdot 3 = 9$ . (EE.2)

**Perfect square:** A number with a square root that is a rational number. (EE.2)

**Cube root:** One of three equal factors that equals a nonnegative number. For example,  $\sqrt[3]{27} = 3$  because  $3^3 = 3 \cdot 3 \cdot 3 = 27$ . (EE.2)

**Scientific notation:** A product of a number (between 1 and 10) and a power of 10. (EE.3)

Perform **operations** (add, subtract, multiply, and divide) with numbers containing exponents, including scientific notation. Scientific notation represents one value that can be added, subtracted, multiplied, and divided using the strategies for operations on multi-digit whole numbers and decimals. (EE.4)

Solve **linear equations** that include one **variable**. The linear equations can include **coefficients** or use the variable on both sides of the equation. Use the **properties of operations** including the **distributive property**, **addition property of equality**, and the **multiplication property of equality** to find the solution to the equation. (EE.7)

**Distributive property:** Multiplies a factor that is outside of a set of parentheses with each addend within the parentheses to solve. (EE.7)

**Addition property of equality:** Adding the same number or value to both sides of an equation results in equivalent equations. (EE.7)

**Multiplication property of equality:** Multiplying the same number or value to both sides of an equation results in equivalent equations. (EE.7)

**Rational number:** A ratio of two integers written as a repeating or terminating decimal. (NS.1)

**Irrational number:** A number that cannot be written as the ratio of two integers and is a nonrepeating and nonterminating decimal. (NS.1)

To **compare** irrational numbers, approximate the value of the **irrational numbers** and place on the **number line** between the nearest rational numbers. An **approximation** of an irrational number can also be used to **estimate** the value of an expression containing an irrational number. For example,  $5 \cdot \sqrt{2}$  can be estimated using  $5 \cdot 1.4 = 7$ . (NS.2)



**Important Tip**

- ✍ Scientific notation is used to represent numbers that are very large or very small. The power of 10 can have a positive exponent to represent larger numbers. For example,  $3 \times 10^3 = 3,000$ . The power of 10 can also have a negative exponent to represent smaller numbers. For example,  $3 \times 10^{-3} = 3 \cdot \frac{1}{10^3} = 0.003$ .

**Sample Items 4–6****Item 4**

Between which two integers is the value of  $\sqrt{21}$ ?

- A. 0 to 1
- B. 4 to 5
- C. 6 to 7
- D. 10 to 11

**Item 5**

A grain of sand has a mass of approximately  $6 \times 10^{-2}$  grams. Earth has a mass of approximately  $6 \times 10^{28}$  grams.

How many times smaller is the mass of the grain of sand than the mass of Earth?

- A.  $1 \times 10^{-54}$
- B.  $1 \times 10^{-14}$
- C.  $1 \times 10^{26}$
- D.  $1 \times 10^{30}$



## Unit 3: Geometric Applications of Exponents

In this unit, you will work with the Pythagorean theorem and determine the lengths of sides of triangles. You will determine the distance between two points on a grid and find the volume of three-dimensional figures. You will learn to simplify expressions that include exponents, squares, cubes, square roots, and cubed roots using the properties of operations.

### KEY TERMS

**Pythagorean theorem:** States that the squared length of the hypotenuse in a right triangle equals the sum of the squared lengths of the other two sides. This is often written as  $a^2 + b^2 = c^2$ . (G.6)

The **converse of the Pythagorean theorem** states that if the squared length of the longest side is equal to the sum of the squared length of the two shorter sides, then the triangle is a right triangle. (G.6)

The formula for the **Pythagorean theorem** can be used to determine unknown side lengths in a right triangle by inserting both known lengths into the formula and solving for the variable. (G.7)

The formula for the **Pythagorean theorem** can be used to determine the distance between two points by creating a right triangle along the coordinate grid. The distance between the two points is the length of the hypotenuse. (G.8)

**Volume:** The amount of space that an object or a three-dimensional figure occupies.

- **Cone:** A figure with one vertex and a circular or elliptical base. Find the volume using  $V = \frac{1}{3} \pi r^2 h$ .
- **Sphere:** A figure that has all points equidistant from the center. Find the volume using  $V = \frac{4}{3} \pi r^3$ .
- **Cylinder:** A figure that has two congruent circular bases that are parallel. Find the volume using  $V = \pi r^2 h$ . (G.9)

Simplify **expressions** that include **exponents, squares, cubes, square roots, and cubed roots** using the properties of operations.

- **Distributive property** multiplies a factor that is outside of a set of parentheses with each addend within the parentheses to solve.
- **Commutative property** allows for addends in an addition equation or factors in a multiplication equation to be moved or placed in a different order while solving.
- **Associative property** allows for addends in addition equations or factors in multiplication equations to be grouped together into different pairs while solving.
- **Identity property** allows for 0 to be added or 1 to be multiplied by any number and the number remains the same.
- **Inverse property** allows a number to be added to the opposite number for a sum of 0. Also, a number multiplied by the reciprocal fraction has a product of 1. (EE.2)

The square or cubed root of a number can be a **rational** or an **irrational number**. In the case of irrational numbers, use the **radical** or **cubed root symbol** in the solution to the equation. For example,  $x = \sqrt{2}$ . The value of the square or cubed root can also be approximated to the nearest rational number. (EE.2)

**Rational number:** A ratio of two integers that can be written as a repeating or terminating decimal. (EE.2)

**Irrational number:** A number that cannot be written as the ratio of two integers and is a nonrepeating and nonterminating decimal. (EE.2)

**Important Tip**

 The value cubed is the inverse operation of the cubed root, and a value squared is the inverse operation of a square root.

**Sample Items 7–9**

**Item 7**

Jenna wants to hang outdoor stringed lights on her house along the roof line and horizontally across, connecting the ends of the roof line to create a triangle.

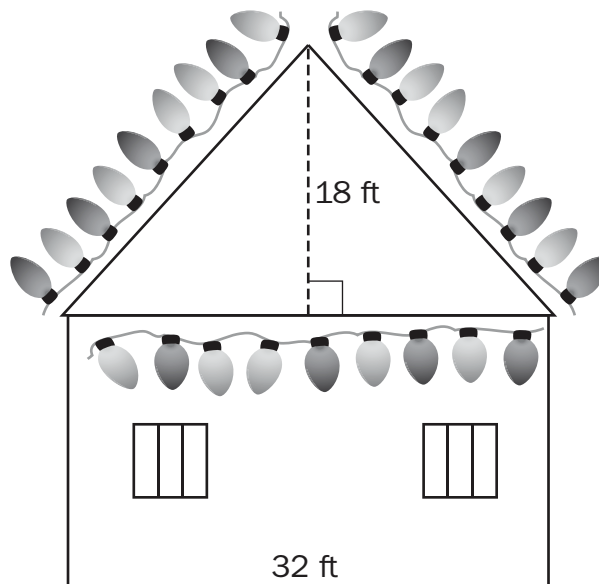

**What is the approximate total length, in feet, of lights that she needs to create one triangle?**

- A. 48 feet
- B. 64 feet
- C. 80 feet
- D. 98 feet

**Item 8**

For a classroom party, there are 12 bottles of fruit punch. Each bottle is filled with 850 cubic centimeters of punch. The fruit punch will be served in cone-shaped paper cups that are 7 centimeters across and 12 centimeters tall.

How many completely full cone-shaped cups of the punch can be poured?

- A. 16
- B. 66
- C. 232
- D. 265

**Item 9**

Look at the right triangle on the coordinate grid.

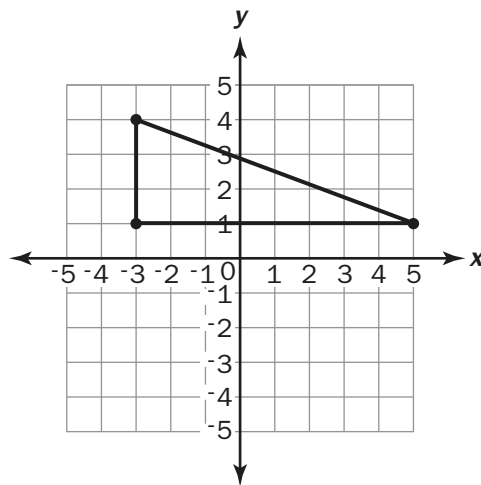

What is the length of the hypotenuse?

- A.  $\sqrt{11}$  units
- B.  $\sqrt{24}$  units
- C.  $\sqrt{55}$  units
- D.  $\sqrt{73}$  units

## Unit 4: Functions

In this unit, you will work with functions. Functions produce input and output values. You can also graph functions. Functions can be represented numerically, graphically, verbally, and algebraically.

### KEY TERMS

**Function:** A relationship between two sets of numbers, where one input value has only one output value. (F.1)

A function can be graphed using the input values as the  $x$ -coordinates and the output values as the  $y$ -coordinates. The **graph of the function** includes all points on the coordinate plane that make the function true. (F.1)

A function produces one **output** value for one **input** value. A **counterexample** can show an equation where one value can be input and produce two values as output. These counterexamples are not functions. (F.1)

**Domain:** The set of all  $x$ -coordinates in the ordered pairs that represent a relationship between numbers. This represents the input or **independent** value. (F.1)

**Range:** The set of all  $y$ -coordinates in the ordered pairs that represent a relationship between numbers. This represents the output or **dependent** value. (F.1)

**Functions** can be represented in four ways:

- **Numerically:** A function can be represented as numbers in an input/output table.
- **Graphically:** A function can be graphed on the coordinate plane using ordered pairs: (input, output).
- **Verbally:** The relationship between numbers in a function can be written in words.
- **Algebraically:** A function can be written as an equation involving variables. (F.2)

Compare the properties of two different functions written in any form to find which function has a greater **rate of change**. (F.2)

### Important Tip

 When listing the domain and range of a relation, list each  $x$ -coordinate value for the domain without duplicating numbers. List each  $y$ -coordinate value for the range without duplicating numbers. In a list that contains a repeated domain value that is paired with more than one range value, the relation is not a function. This is true because the input, or  $x$ -coordinate value, has produced more than one output, or  $y$ -coordinate value.

## Sample Items 10–12

## Item 10

Which of these functions has a greater rate of change than the function  $y = 5.6x + 7$ ?

A.

x	y
-1	-10
0	-4
1	2
2	8

B.  $y = \frac{7}{3}x - 2$

C.

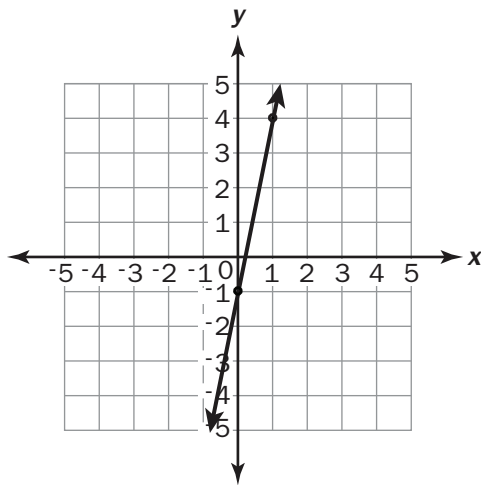

D.  $y = -6x + 10$







## Unit 5: Linear Functions

In this unit, you will work with ratios, slope, graphs, and linear functions. You will compare two proportional relationships using the unit rate as the slope. You will compare proportional relationships and determine the rate of change.

### KEY TERMS

**Proportional relationship:** A relationship between two ratios that are equivalent. (EE.5)

**Slope:** The steepness of a line, also the **unit rate** in proportional relationships. (EE.5)

**Graph** proportional relationships on the **coordinate plane** using the **unit rate** as the slope. (EE.5)

**Compare** two proportional relationships that are written in different **forms**, including graphed on the coordinate plane or written as an equation. Determine the proportional relationship that has the greater **rate of change**. (EE.5)

**Slope** can be determined using any two points on a **straight line** by finding the **ratio** between the **vertical rise** of the line and the **horizontal run** of the line. For example, a line that passes through (0, 0) and (4, 1) has a vertical rise of 1 and a horizontal run of 4, so the slope of the line is  $\frac{1}{4}$ . (EE.6)

A **straight line** continues at the same steepness, or **slope**, through its entire length. The measure of the slope is the same between any two points on the line. (EE.6)

The **slope** of the side lengths will remain the same between **similar triangles**. This can be proven using the endpoints of corresponding sides to determine and compare the slopes. (EE.6)

**Linear function:** A function that produces a straight line when graphed on the coordinate plane. The linear function can be written as an equation in slope-intercept form.

- **$y = mx$ :** the slope-intercept form of a line going through the origin, where  $m$  represents the slope.
- **$y = mx + b$ :** the slope-intercept form of a line that crosses the  $y$ -axis at  $b$ , where  $m$  represents the slope. (F.3)

### Important Tips

- ✍ A straight line on a coordinate plane can be vertical, horizontal, or diagonal.
- ✍ The slope of a line can be determined using any two points on the line by writing the ratio of the vertical rise to the horizontal run. The ratio written as a fraction can then be reduced to represent the slope if necessary. For example, a line going through the points (1, 2) and (9, 6) has a slope of  $\frac{4}{8}$ , which can be reduced to  $\frac{1}{2}$ .

---

**Sample Items 13–15****Item 13**

Which equation represents a nonlinear function?

- A.  $y = 3x^3$
- B.  $3x + 2y = 10$
- C.  $y = 15.3$
- D.  $y = \frac{1}{4}x - 2$

**Item 14**

Look at  $\triangle ABC$  with coordinates  $A(-1, -1)$ ,  $B(2, 3)$ , and  $C(2, -1)$ .

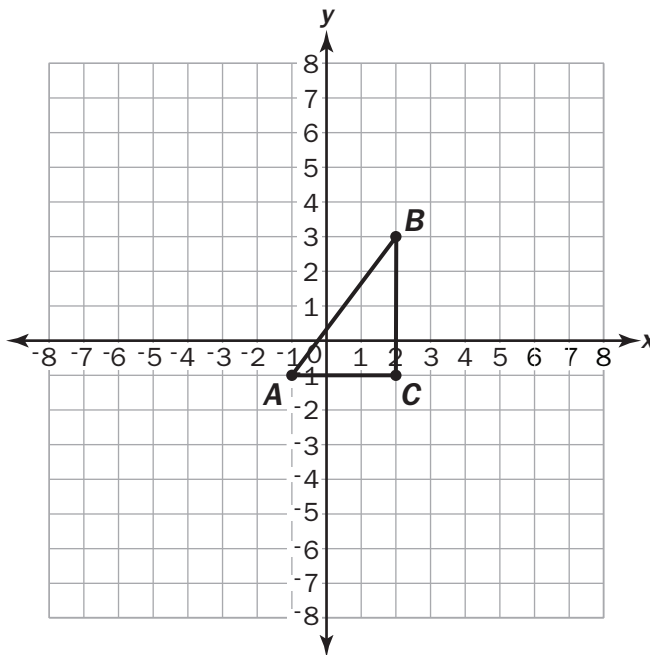

**Part A:** The ordered pair  $(5, y)$  defines the location of point  $F$ , which is on line  $AB$ . What is the value of  $y$  for this ordered pair?

---

**Part B:** If you move 3 units to the right from point  $F$ , how many units up or down do you need to move in order to stay on line  $AB$ ?

---

**Item 15**

Consider this graph that passes through points (0, 0) and (5, 30).

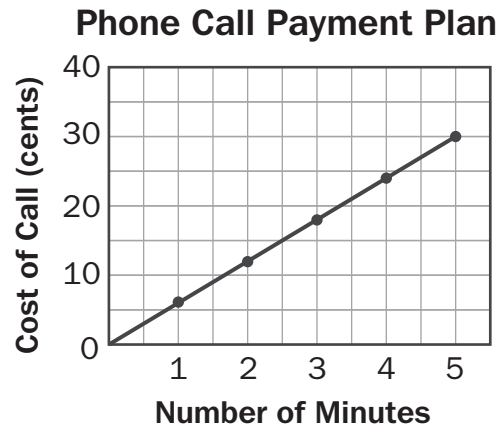

Which equation represents the cost of a phone call  $c$  after  $m$  minutes, according to the payment plan?

- A.  $c = \frac{1}{6}m$
- B.  $c = 6m$
- C.  $c = \frac{1}{30}m$
- D.  $c = 30m$

## Unit 6: Linear Models and Tables

In this unit, you will work with models that are linear functions, the slope, qualitative and quantitative variables, data, and scatter plots. You will also identify the rate of change from tables, graphs, equations, or verbal description. You will describe patterns using bivariate data using different methods, including clustering, associations, and outliers. You will draw a line of best fit and use tables.

### KEY TERMS

**Rate of change:** The ratio used to describe the change in the input and output values within a function. (F.4)

**Model** a linear relationship between values as a **linear function**. Determine the **rate of change**, or **slope**, based on a description of the linear relationship and a starting point  $(x, y)$ . Use this information to **graph** the linear function on the coordinate plane. (F.4)

**Qualitative variable:** A variable with a value that is not numerical—for instance, color, type of animal, or other variable in data collection that is described verbally. (F.5)

**Quantitative variable:** A variable with a value that is numerical—for instance, length, temperature, or other variable in data collection that is described numerically. (SP.2)

**Bivariate data:** Two response variables from data collection within the same population. For example, height and weight of dogs, with the height being an independent variable and the weight being a dependent variable related to the height. (SP.1)

**Scatter plot:** A graph placing a point for each **ordered pair** representing the bivariate data. Conclusions about a **data set** can be drawn using the visual representation of the scatter plot to look for relationships between values. (SP.1)

Describe **patterns** in bivariate data using:

- **Clustering:** breaking a data set into smaller groups that share a common trait or similarity.
- **Outliers:** pieces of data that stand out from the rest of the data set.
- **Positive association:** data that increase together; the data points rise from the lower left side to the upper right side of the graph.
- **Negative association:** data with one variable that increases while the other variable decreases; the data points fall from the upper left side to the lower right side of the graph.
- **Linear association:** a relationship that is represented using a straight line, such as a linear function.
- **Nonlinear association:** a relationship that is not represented by a straight line. (SP.1)

**Line of best fit:** A straight line drawn on a scatter plot that passes through the center of the group of data points. (SP.2)

**Bivariate data** can be used to create **graphs** and **linear equations** based on the slope and intercept of the line. (SP.3)

A **two-way table** can be used to represent bivariate data, including the **frequencies** of data occurring. Use the two-way table to identify **positive** or **negative association** between variables. (SP.4)

### Important Tips

- ✍ A pattern in the data set can be used to predict the outcomes of other variables.
- ✍ The relationship between values can be represented using tables, graphs, and equations using the slope and  $y$ -intercept.

## Sample Items 16–18

### Item 16

This table of values represents a linear function.

$x$	$y$
0	80
4	60
8	40
12	20

**Part A:** Is the rate of change of this function  $-5$ ? Explain how you know.

---

---

---

**Part B:** What is the initial value of this function?

---

**Item 17**

Look at the scatter plot showing the relationship between the average daily temperature and the number of visitors at a beach.

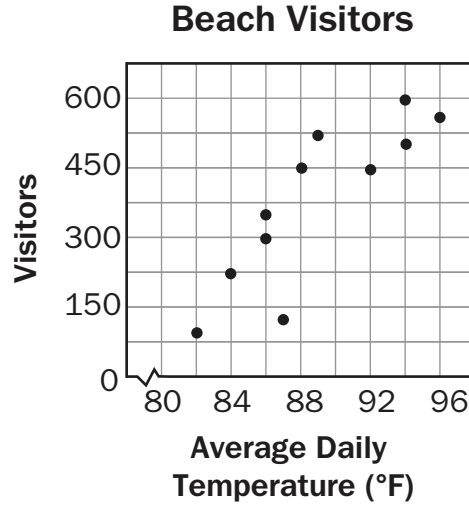

What is the pattern of association shown by the data?

- A. no association
- B. positive association
- C. negative association
- D. nonlinear association



Item 18

Which straight line BEST fits the data for the scatter plot?

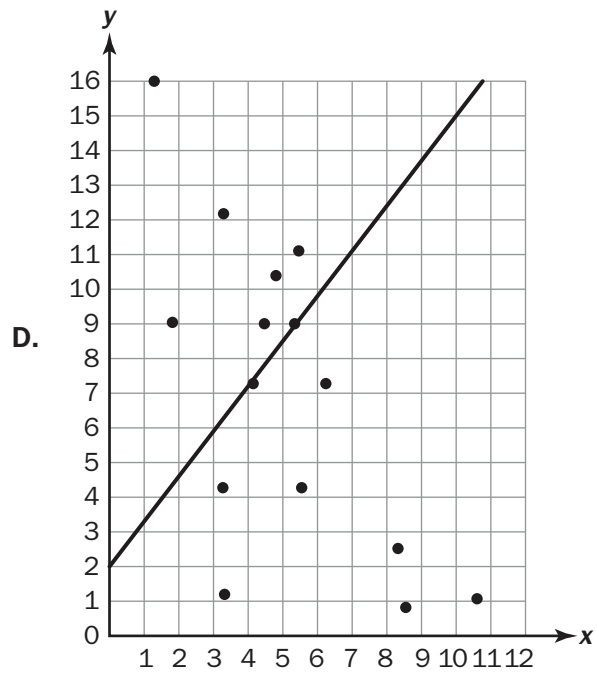
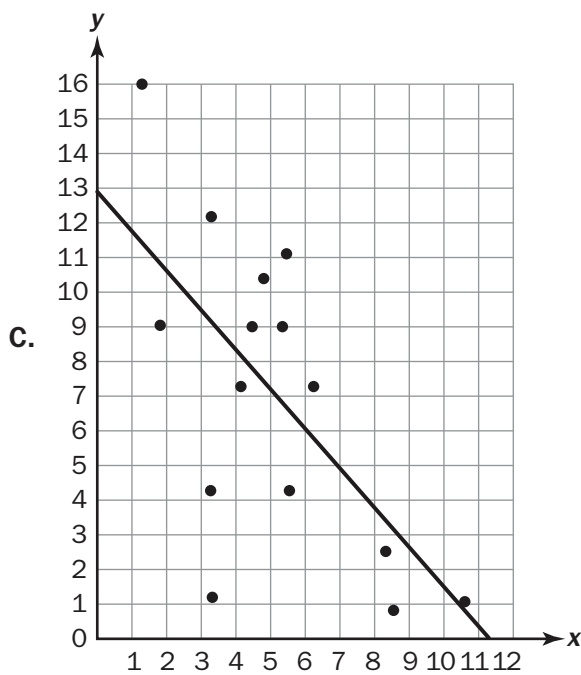
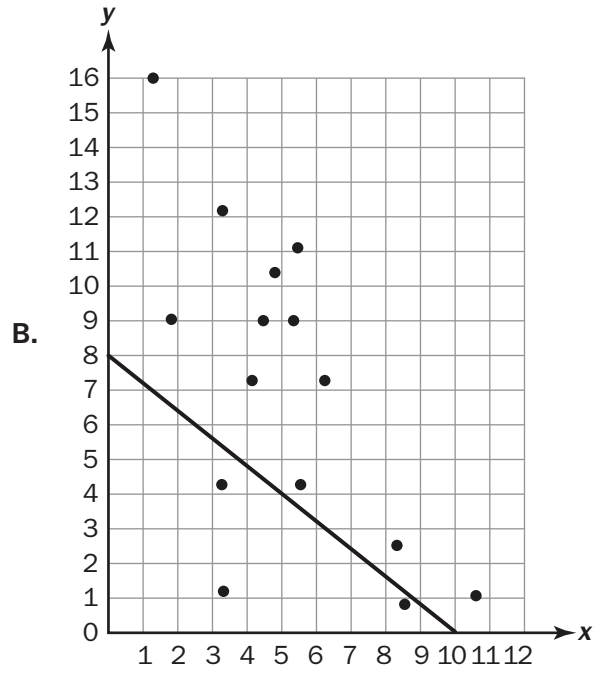
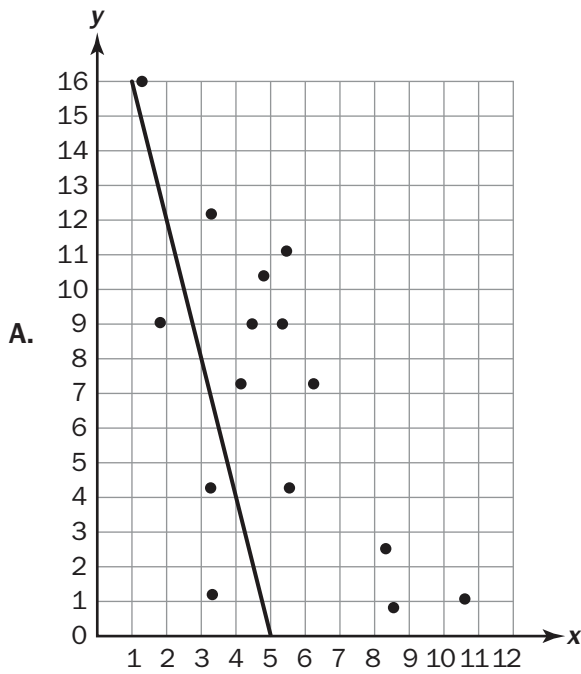

## Unit 7: Solving Systems of Equations

In this unit, you will work with systems of equations to define relationships between variables. You will find the solutions to systems of equations. You will learn about parallel, co-linear, and intersecting lines and about how to solve systems of equations algebraically.

### KEY TERMS

**System of equations:** Multiple equations that work together to define the relationship between variables. (EE.8a)

The **solution** to a system of equations can be represented by graphing the line of solutions for each equation. The point or points where the lines **intersect** on the **coordinate plane** show the valid solutions to all of the equations in the system. (EE.8a)

**Parallel lines:** Two lines that have the same slope and do not intersect. A system of equations that produces two parallel lines has no solution. (EE.8b)

**Collinear lines:** Two lines that share all of the same points. A system of equations that produces two co-linear lines has an infinite number of solutions. (EE.8b)

Systems of equations can also be solved **algebraically** by completing the operations on each side of the equation using the **addition property of equality** and **multiplication property of equality**. (EE.8b)

**Addition property of equality:** Adding the same number or value to both sides of an equation results in equivalent equations. (EE.8b)

**Multiplication property of equality:** Multiplying the same number or value to both sides of an equation results in equivalent equations. (EE.8b)

Use systems of equations in **real-world situations** by determining the solution or set of solutions that will satisfy a set of equations. A solution can also be determined based on **sets of points**. Given two sets of points, draw the corresponding line for each set and identify any locations where the lines intersect. (EE.8c)

### Important Tip

 The number of solutions to a system of equations can be no solution, one solution, or multiple solutions, including an infinite number of solutions.

---

**Sample Items 19–21****Item 19**

Consider this system of equations.

$$\begin{aligned} -7x + 8y &= 1 \\ 4x - 8y &= 20 \end{aligned}$$

What is the  $y$ -coordinate of the solution for this system?

- A.  $-1$
- B.  $-6$
- C.  $1$
- D.  $6$

**Item 20**

Consider this system of equations.

$$y = -2x - 1$$

$$y = \frac{1}{2}x + 4$$

Which graph represents the solution of the system?

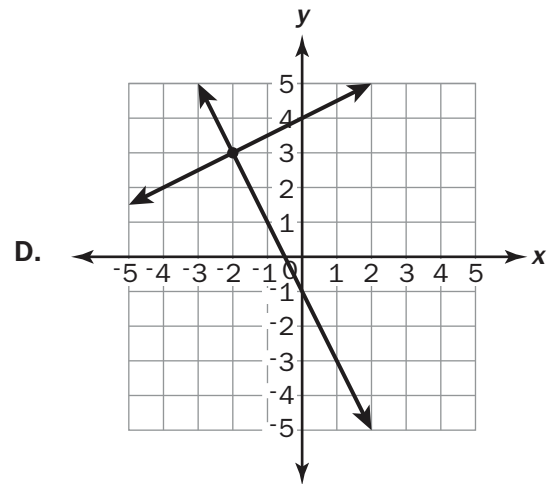
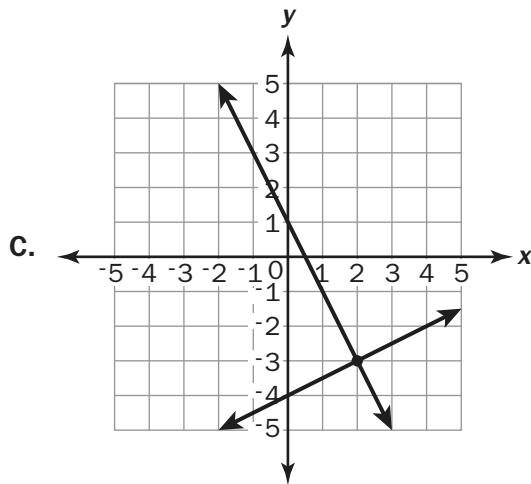
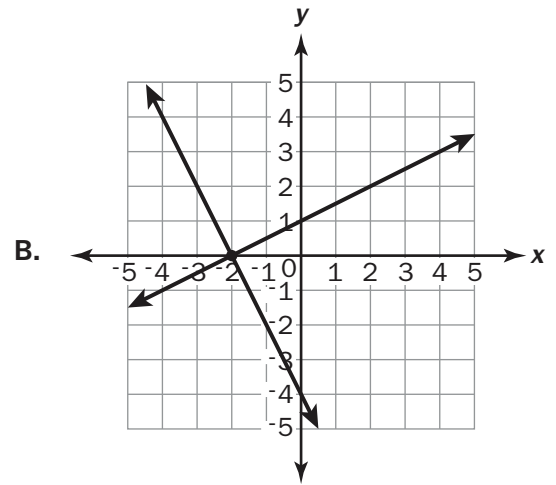
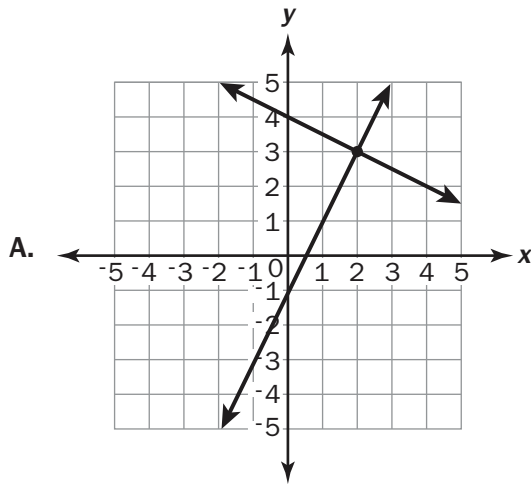

**Item 21**

Which system of equations has exactly one solution?

- A.  $5x - y = -3$   
 $5x - y = -2$
- B.  $8x - 3y = -12$   
 $x - 3y = 9$
- C.  $3x - y = 4$   
 $9x - 3y = 12$
- D.  $2x - y = 3$   
 $2x - y = -4$

## MATHEMATICS ADDITIONAL SAMPLE ITEM KEYS

Item	Standard/ Element	DOK Level	Correct Answer	Explanation
1	MGSE8.G.1	2	C	The correct answer is choice (C) because the before and after segments have the same x-coordinates and opposite y-coordinates. Choice (A) is incorrect because the before and after segments are congruent, while a dilation by a factor of $\frac{1}{2}$ would make the after segment half the length of the before segment. Choice (B) is incorrect because rotation would not result in the vertices having the same x-coordinates. Choice (D) is incorrect because the line segment was translated 6 units down, but it was not translated 1 unit to the left.
2	MGSE8.G.3	3	N/A	See scoring rubric beginning on page 113 and sample response on page 115.
3	MGSE.8.G3	2	C	The correct answer is choice (C) because it follows the correct sequence of transformations. Choice (A) is incorrect because it is translated and only the right endpoint is reflected. Choice (B) is incorrect because it is reflected without the translation. Choice (D) is incorrect because it is reflected first and then translated.
4	MGSE8.N.S.2	2	B	The correct answer is choice (B) because 21 falls between 16 and 25, the perfect squares of 4 and 5. Choice (A) is incorrect because it does not show understanding that the number is not a fractional value. Choice (C) is incorrect because the square of all the values in this range is greater than 21. Choice (D) is incorrect because it is the result of dividing 21 by 2.
5	MGSE8.EE.3	1	D	The correct answer is choice (D). The exponents are subtracted because these two numbers are being divided. Choice (A) is incorrect because the exponents are multiplied together. Choice (B) is incorrect because the exponents are divided. Choice (C) is incorrect because the exponents are added together.
6	MGSE8.EE.1	2	N/A	See scoring rubric on page 115 and sample response on page 116.
7	MGSE8.G.8	2	C	The correct answer is choice (C) because each slanted side length = $\sqrt{18^2 + 16^2} \approx 24$ . So the perimeter of the triangle $\approx 24 + 24 + 32 = 80$ ft. Choice (A) is incorrect because only the slants of the roof are calculated, without including the horizontal distance. Choice (B) is incorrect because the slants of the roof are calculated without doubling the horizontal distance to cover both right triangles. Choice (D) is incorrect because the height of the triangle is included in the total length.

Item	Standard/ Element	DOK Level	Correct Answer	Explanation
8	MGSE8.G.9	2	B	The correct answer is choice (B) because the volume of each cup is $\frac{1}{3} \pi (3.5)^2(12) \approx 154$ cm. There is a total of $12.850 = 10,200$ cm <sup>3</sup> of punch. So $10,200 \div 154 \approx 66$ cups can be filled. Choice (A) is incorrect because the diameter was mistakenly used. Choice (C) is incorrect because the radius was not squared in the calculations. Choice (D) is incorrect because half the radius was mistakenly used in the formula.
9	MGSE8.G.8	2	D	The correct answer is choice (D) because the length of the hypotenuse = $\sqrt{8^2 + 3^2} = \sqrt{73}$ . Choice (A) is incorrect because the legs were not squared before finding the hypotenuse value. Choice (B) is incorrect because it is the square root of the product of two legs. Choice (C) is incorrect because the squares of the leg values are subtracted instead of added.
10	MGSE8.F.2	2	A	The correct answer is choice (A) because it has the greatest rate of change, which is 6. Choice (B) is incorrect because the rate of change is 2.3. Choice (C) is incorrect because the rate of change is 5. Choice (D) is incorrect because it has the rate of change as -6.
11	MGSE8.F.1	2	N/A	See scoring rubric on page 117 and sample response on page 118.
12	MGSE8.F.2	2	N/A	See scoring rubric on page 119 and sample response on page 120.
13	MGSE8.F.3	1	A	The correct answer is choice (A) because the exponent of 3 causes the graph to be a curve. Choice (B) is a straight line when graphed. Choice (C) is a straight line when graphed. Choice (D) is a straight line when graphed.
14	MGSE8.EE.6	2	N/A	See scoring rubric on page 121 and sample response on page 122.
15	MGSE8.EE.6	2	B	The correct answer choice is (B) because every minute costs 6 cents. Choice (A) is incorrect because the line was interpreted with the x-value read before the y-value. Choice (C) is incorrect because the slope was misinterpreted to have a rise of 1 and a run of 30. Choice (D) is incorrect because, though there is a point with the rise of 30, the run was not interpreted.

Item	Standard/ Element	DOK Level	Correct Answer	Explanation
16	MGSE8.F.4	2	N/A	See scoring rubric on page 123 and sample response on page 124.
17	MGSE8.SP.1	1	B	The correct answer choice is (B) because the scatter plot shows the warmer the temperatures the more visitors there are. Choice (A) is incorrect because there is an association because the dots are clustered together near a line of best fit. Choice (C) is incorrect because a negative association would mean that as the temperature gets warmer, the number of visitors goes down. Choice (D) is incorrect because the points seem to follow a linear pattern.
18	MGSE8.SP.2	2	C	The correct answer is choice (C) because the points are distributed evenly above and below the line. Choice (A) and choice (B) are not correct because, though they show a negative slope with a line of best fit, the points are not distributed equally above and below the line of best fit. Choice (D) is incorrect because the line of best fit shows a positive slope that does not match the pattern of the data points.
19	MGSE8.EE.8b	2	B	The correct answer is choice (B) because $-6$ is the $y$ -coordinate of the point that makes both equations true. Choice (A) is incorrect because the rules for integer operations were not followed, though the steps were performed correctly. Choice (C) is incorrect because the integer sign rules were not followed initially, but the steps thereafter are correct. Choice (D) is incorrect because the integer rules were not followed.
20	MGSE8.EE.8a	2	D	The correct answer is choice (D) because the solution to both the system of equations and the graph is $(-2, 3)$ . Choice (A) is incorrect because the graph has correct $y$ -intercepts but incorrect slopes. Choice (B) is incorrect because the graph has incorrect slopes but correct $y$ -intercepts. Choice (C) is incorrect because the $y$ -intercepts are incorrect, though the graph has the correct slopes.
21	MGSE8.EE.8b	2	B	The correct answer is choice (B) because the solution is $(-3, -4)$ . Choice (A), choice (C), and choice (D) are all systems with no solution or infinitely many solutions.



## MATHEMATICS SAMPLE SCORING RUBRICS AND EXEMPLAR RESPONSES

### Item 2

#### Scoring Rubric

Points	Description
4	<p>The response achieves the following:</p> <ul style="list-style-type: none"> <li>• The response demonstrates a complete understanding of applying a sequence of transformations to obtain a similar figure.</li> <li>• Give 4 points for four parts answered correctly.               <ul style="list-style-type: none"> <li>• Response is correct and complete.</li> <li>• Response shows application of a reasonable and relevant strategy.</li> </ul> </li> <li>• Mathematical ideas are expressed coherently through a clear, complete, logical, and fully developed response using words, calculations, and/or symbols, as appropriate.</li> </ul>
3	<p>The response achieves the following:</p> <ul style="list-style-type: none"> <li>• The response demonstrates a nearly complete understanding of applying a sequence of transformations to obtain a similar figure.</li> <li>• Give 3 points for three parts answered correctly OR for correct answers for four parts but no explanation given for either Part C or Part D.               <ul style="list-style-type: none"> <li>• Response is mostly correct but contains either a computational error or an unclear or incomplete explanation.</li> <li>• Response shows application of a relevant strategy, though it may be only partially applied or remain unexplained.</li> </ul> </li> <li>• Mathematical ideas are expressed only partially using words, calculations, and/or symbols, as appropriate.</li> </ul>
2	<p>The response achieves the following:</p> <ul style="list-style-type: none"> <li>• The response demonstrates a partial understanding of applying a sequence of transformations to obtain a similar figure.</li> <li>• Give 2 points for two parts answered correctly OR for correct answers for four parts but no explanations given for both Part C and Part D.               <ul style="list-style-type: none"> <li>• Response is only partially correct.</li> <li>• Response shows application of a relevant strategy, though it may be only partially applied or remain unexplained.</li> </ul> </li> <li>• Mathematical ideas are expressed only partially using words, calculations, and/or symbols, as appropriate.</li> </ul>

Points	Description
1	<p>The response achieves the following:</p> <ul style="list-style-type: none"> <li>• The response demonstrates a minimal understanding of applying a sequence of transformations to obtain a similar figure.</li> <li>• Give 1 point for one part answered correctly.               <ul style="list-style-type: none"> <li>• Response is only partially correct.</li> <li>• Response shows incomplete or inaccurate application of a relevant strategy.</li> </ul> </li> <li>• Mathematical ideas are expressed only partially using words, calculations, and/or symbols, as appropriate.</li> </ul>
0	<p>The response achieves the following:</p> <ul style="list-style-type: none"> <li>• The response demonstrates limited to no understanding of applying a sequence of transformations to obtain a similar figure.               <ul style="list-style-type: none"> <li>• Response is incorrect.</li> <li>• Response shows no application of a strategy.</li> </ul> </li> <li>• Mathematical ideas cannot be interpreted or lack sufficient evidence to support even a limited understanding.</li> </ul>

**Exemplar Response**

<b>Points Awarded</b>	<b>Sample Response</b>
4	Part A: Figure is translated 1 unit up and 4 units to the right. Part B: Figure is translated 4 units to the right and 2 units down. Part C: Figure is dilated by a scale factor of 2. Part D: Yes. You could translate the quadrilateral $A'B'C'D'$ first (by different amounts) and then dilate it by 2. <i>Or other valid explanation</i>
3	The student correctly answers three out of the four parts.
2	The student correctly answers two out of the four parts.
1	The student correctly answers one of the four parts.
0	<i>Response is irrelevant, inappropriate, or not provided.</i>

Item 6

Scoring Rubric

Points	Description
2	<p>The response achieves the following:</p> <ul style="list-style-type: none"> <li>• Response demonstrates a complete understanding of applying properties of integer exponents to perform operations.</li> <li>• Give 2 points for Part A correct AND Part B correct.               <ul style="list-style-type: none"> <li>• Response is correct and complete.</li> <li>• Response shows application of a reasonable and relevant strategy.</li> </ul> </li> <li>• Mathematical ideas are expressed coherently through a clear, complete, logical, and fully developed response using words, calculations, and/or symbols, as appropriate.</li> </ul>
1	<p>The response achieves the following:</p> <ul style="list-style-type: none"> <li>• Response demonstrates a partial understanding of applying properties of integer exponents to perform operations.</li> <li>• Give 1 point for Part A OR Part B correct.               <ul style="list-style-type: none"> <li>• Response is mostly correct but contains either a computational error or an unclear or incomplete explanation.</li> <li>• Response shows application of a relevant strategy, though it may be only partially applied or remain unexplained.</li> </ul> </li> <li>• Mathematical ideas are expressed only partially using words, calculations, and/or symbols, as appropriate.</li> </ul>
0	<p>The response achieves the following:</p> <ul style="list-style-type: none"> <li>• The response demonstrates limited to no understanding of applying properties of integer exponents to perform operations.               <ul style="list-style-type: none"> <li>• Response is incorrect.</li> <li>• Response shows no application of a strategy.</li> </ul> </li> <li>• Mathematical ideas cannot be interpreted or lack sufficient evidence to support even a limited understanding.</li> </ul>

**Exemplar Response**

<b>Points Awarded</b>	<b>Sample Response</b>
2	Part A: 343 or $7^3$ or equivalent Part B: I found the answer by adding the exponents because the two factors have the same base. The result is 7 to the third power, which equals 343.
1	Part A: 6 Part B: By adding them together
0	<i>Response is irrelevant, inappropriate, or not provided.</i>

## Item 11

## Scoring Rubric

Points	Description
2	<p>The response achieves the following:</p> <ul style="list-style-type: none"> <li>• Response demonstrates a complete understanding of functions as the set of ordered pairs consisting of an input and the corresponding output.</li> <li>• Give 2 points for Part A correct AND Part B correct.               <ul style="list-style-type: none"> <li>• Response is correct and complete.</li> <li>• Response shows application of a reasonable and relevant strategy.</li> </ul> </li> <li>• Mathematical ideas are expressed coherently through a clear, complete, logical, and fully developed response using words, calculations, and/or symbols, as appropriate.</li> </ul>
1	<p>The response achieves the following:</p> <ul style="list-style-type: none"> <li>• Response demonstrates a partial understanding of functions as the set of ordered pairs consisting of an input and the corresponding output.</li> <li>• Give 1 point for Part A OR Part B correct.               <ul style="list-style-type: none"> <li>• Response is mostly correct but contains either a computational error or an unclear or incomplete explanation.</li> <li>• Response shows application of a relevant strategy, though it may be only partially applied or remain unexplained.</li> </ul> </li> <li>• Mathematical ideas are expressed only partially using words, calculations, and/or symbols, as appropriate.</li> </ul>
0	<p>The response achieves the following:</p> <ul style="list-style-type: none"> <li>• The response demonstrates limited to no understanding of functions as a set of ordered pairs consisting of an input and corresponding output.               <ul style="list-style-type: none"> <li>• Response is incorrect.</li> <li>• Response shows no application of a strategy.</li> </ul> </li> <li>• Mathematical ideas cannot be interpreted or lack sufficient evidence to support even a limited understanding.</li> </ul>

**Exemplar Response**

<b>Points Awarded</b>	<b>Sample Response</b>
2	Part A: Table D Part B: It is not a function because the same value of $x$ has two different output values and a function can have only one unique output for every input.
1	Part A: Table D Part B: It is not a function.
0	<i>Response is irrelevant, inappropriate, or not provided.</i>

**Item 12**

**Scoring Rubric**

Points	Description
2	<p>The response achieves the following:</p> <ul style="list-style-type: none"> <li>• Response demonstrates a complete understanding of comparing properties of two functions represented in different ways.</li> <li>• Give 2 points for Part A correct AND Part B correct.               <ul style="list-style-type: none"> <li>• Response is correct and complete.</li> <li>• Response shows application of a reasonable and relevant strategy.</li> </ul> </li> <li>• Mathematical ideas are expressed coherently through a clear, complete, logical, and fully developed response using words, calculations, and/or symbols, as appropriate.</li> </ul>
1	<p>The response achieves the following:</p> <ul style="list-style-type: none"> <li>• Response demonstrates a partial understanding of comparing properties of two functions represented in different ways.</li> <li>• Give 1 point for Part A OR Part B correct.               <ul style="list-style-type: none"> <li>• Response is mostly correct but contains either a computational error or an unclear or incomplete explanation.</li> <li>• Response shows application of a relevant strategy, though it may be only partially applied or remain unexplained.</li> </ul> </li> <li>• Mathematical ideas are expressed only partially using words, calculations, and/or symbols, as appropriate.</li> </ul>
0	<p>The response achieves the following:</p> <ul style="list-style-type: none"> <li>• The response demonstrates limited to no understanding of comparing properties of two functions represented in different ways.               <ul style="list-style-type: none"> <li>• Response is incorrect.</li> <li>• Response shows no application of a strategy.</li> </ul> </li> <li>• Mathematical ideas cannot be interpreted or lack sufficient evidence to support even a limited understanding.</li> </ul>



**Exemplar Response**

<b>Points Awarded</b>	<b>Sample Response</b>
2	Part A: The equation represents the function with the greater rate of change. Part B: The rate of change for the table is 3. I know because as the value of $x$ increases by 1, the value of $y$ increases by 3. The rate of change for the equation is 5. I know because the equation is in slope-intercept form and the slope, $m$ , is 5. Since 5 is greater than 3, the equation has the greater rate of change.
1	Part A: The equation represents the function with the greater rate of change. Part B: I know because the initial value of the equation is greater than the initial value for the table.
0	<i>Response is irrelevant, inappropriate, or not provided.</i>

**Item 14**

**Scoring Rubric**

Points	Description
2	<p>The response achieves the following:</p> <ul style="list-style-type: none"> <li>• Response demonstrates a complete understanding of using similar triangles to define the slope between any two points and writing an equation of the line using the slope.</li> <li>• Give 2 points for Part A correct AND Part B correct.               <ul style="list-style-type: none"> <li>• Response is correct and complete.</li> <li>• Response shows application of a reasonable and relevant strategy.</li> </ul> </li> <li>• Mathematical ideas are expressed coherently through a clear, complete, logical, and fully developed response using words, calculations, and/or symbols, as appropriate.</li> </ul>
1	<p>The response achieves the following:</p> <ul style="list-style-type: none"> <li>• Response demonstrates a partial understanding of using similar triangles to define slope between any two points and writing an equation of the line using the slope.</li> <li>• Give 1 point for Part A OR Part B correct.               <ul style="list-style-type: none"> <li>• Response is mostly correct but contains either a computational error or an unclear or incomplete explanation.</li> <li>• Response shows application of a relevant strategy, though it may be only partially applied or remain unexplained.</li> </ul> </li> <li>• Mathematical ideas are expressed only partially using words, calculations, and/or symbols, as appropriate.</li> </ul>
0	<p>The response achieves the following:</p> <ul style="list-style-type: none"> <li>• The response demonstrates limited to no understanding of using similar triangles to define slope between any two points and writing an equation of the line using the slope.               <ul style="list-style-type: none"> <li>• Response is incorrect.</li> <li>• Response shows no application of a strategy.</li> </ul> </li> <li>• Mathematical ideas cannot be interpreted or lack sufficient evidence to support even a limited understanding.</li> </ul>

**Exemplar Response**

<b>Points Awarded</b>	<b>Sample Response</b>
2	Part A: 7 Part B: You must move 4 units up.
1	Part A: 7 Part B: You must move 1 unit up.
0	<i>Response is irrelevant, inappropriate, or not provided.</i>

**Item 16**

**Scoring Rubric**

Points	Description
2	<p>The response achieves the following:</p> <ul style="list-style-type: none"> <li>• Response demonstrates a complete understanding of determining the rate of change and initial value of a function.</li> <li>• Give 2 points for Part A correct AND Part B correct.               <ul style="list-style-type: none"> <li>• Response is correct and complete.</li> <li>• Response shows application of a reasonable and relevant strategy.</li> </ul> </li> <li>• Mathematical ideas are expressed coherently through a clear, complete, logical, and fully developed response using words, calculations, and/or symbols, as appropriate.</li> </ul>
1	<p>The response achieves the following:</p> <ul style="list-style-type: none"> <li>• Response demonstrates a partial understanding of determining rate of change and initial value of a function.</li> <li>• Give 1 point for Part A OR Part B correct.               <ul style="list-style-type: none"> <li>• Response is mostly correct but contains either a computational error or an unclear or incomplete explanation.</li> <li>• Response shows application of a relevant strategy, though it may be only partially applied or remain unexplained.</li> </ul> </li> <li>• Mathematical ideas are expressed only partially using words, calculations, and/or symbols, as appropriate.</li> </ul>
0	<p>The response achieves the following:</p> <ul style="list-style-type: none"> <li>• The response demonstrates limited to no understanding of determining rate of change and initial value of a function.               <ul style="list-style-type: none"> <li>• Response is incorrect.</li> <li>• Response shows no application of a strategy.</li> </ul> </li> <li>• Mathematical ideas cannot be interpreted or lack sufficient evidence to support even a limited understanding.</li> </ul>

**Exemplar Response**

<b>Points Awarded</b>	<b>Sample Response</b>
2	Part A: Yes, that is the correct rate of change. I know because as $x$ increases by 1, $y$ decreases by 5. Part B: 80
1	Part A: Yes, that is the correct rate of change. I know because as $x$ increases by 1, $y$ decreases by 5. Part B: 0
0	<i>Response is irrelevant, inappropriate, or not provided.</i>

## SCIENCE

### DESCRIPTION OF TEST FORMAT AND ORGANIZATION

The Grade 8 Science EOG assessment has a total of 75 selected-response (multiple-choice) items.

The test will be given in two sections.

- You may have up to 70 minutes per section to complete Sections 1 and 2.
- The total estimated testing time for the Grade 8 Science EOG assessment ranges from approximately 90 to 140 minutes.

### CONTENT

The Grade 8 Science EOG assessment will measure the Grade 8 Science standards that are described at [www.georgiastandards.org](http://www.georgiastandards.org). The science items also relate to a Characteristics of Science standard. Because science consists of a way of thinking and investigating and includes a growing body of knowledge about the natural world, you will need to understand the **Characteristics of Science** standards and the **Content** standards for Science. The Characteristics of Science and Nature of Science standards can also be found at [www.georgiastandards.org](http://www.georgiastandards.org).

The content of the assessment covers standards that are reported under these domains:

- Structure of Matter
- Force and Motion
- Energy and Its Transformations

### ITEM TYPES

The Science portion of the Grade 8 EOG assessment consists of selected-response (multiple-choice) items only.

## SCIENCE DEPTH OF KNOWLEDGE EXAMPLE ITEMS

Example items that represent applicable DOK levels of the Science assessment are provided for you on the following pages. The items and explanations of what is expected of you to answer them will help you prepare for the test.

**All example and sample items contained in this guide are the property of the Georgia Department of Education.**

### Example Item 1

**DOK Level 1:** This is a DOK level 1 item because the question requires the student to recall information concerning a known relationship between scientific quantities.

**Science Grade 8 Content Domain:** Structure of Matter

**Standard:** S8P1. Students will examine the scientific view of the nature of matter. c. Describe the movement of particles in solids, liquids, gases, and plasma states.

**Standard:** S8CS9b. Scientific investigations usually involve collecting evidence, reasoning, devising hypotheses, and formulating explanations to make sense of collected evidence.

**Look at the illustrations.**

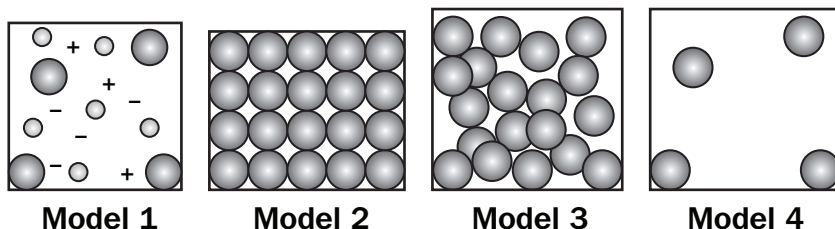

**What illustration shows the structure and movement of particles in a solid?**

- A. 1
- B. 2
- C. 3
- D. 4

**Correct Answer:** B

**Explanation of Correct Answer:** The correct answer is choice (B) 2. Solids are densely packed and vibrate in place. Choice (A) is incorrect because it shows plasma. The particles in plasma move more freely and have electrical charges. Choice (C) is incorrect because it represents a liquid in a container. Particles in a liquid move more freely than those in a solid. Liquids take the shape of their container. Choice (D) is incorrect because it shows a gas. Particles in a gas are spread far apart and move randomly.

## Example Item 2

**DOK Level 2:** This is a DOK level 2 item because the question requires the student to apply learned information to abstract and real-life situations.

**Science Grade 8 Content Domain:** Force and Motion

**Standard:** S8P5. Students will recognize characteristics of gravity, electricity, and magnetism as major kinds of forces acting in nature. a. Recognize that every object exerts gravitational force on every other object and that the force exerted depends on how much mass the objects have and how far apart they are.

**Standard:** S8CS5a. Observe and explain how parts can be related to other parts in a system, such as the role of simple machines in complex machines.

**How would the gravitational force between Earth and the Sun change if Earth's mass were doubled?**

- A. The gravitational force would increase.
- B. The gravitational force would decrease.
- C. The gravitational force would be removed.
- D. The gravitational force would stay the same.

**Correct Answer:** A

**Explanation of Correct Answer:** The correct answer is choice (A) The gravitational force would increase. This question has to do with knowledge of the Law of Gravitation. This law states that the gravitational force of attraction is directly proportional to the product of the objects' masses and inversely proportional to the square of the distance separating them. In this case, by doubling the mass and not changing the distance, it would result in a force that was twice as large. Choice (B) is incorrect because doubling the mass of Earth would result in an increase of the gravitational force between Earth and the Sun. Choice (C) is incorrect. The gravitational force between Earth and the Sun would increase with an increase in both or either mass. Choice (D) is incorrect because according to the law, when the mass is changed the gravitational force will also change.



### Example Item 3

**DOK Level 3:** This is a DOK level 3 item because the question requires the student to make choices based on a reasoned argument.

**Science Grade 8 Content Domain:** Energy and Its Transformations

**Standard:** S8P4. Students will explore the wave nature of sound and electromagnetic radiation. d. Describe how the behavior of waves is affected by medium (such as air, water, solids).

**Standard:** S8CS6b. Write for scientific purposes incorporating information from a circle, bar, or line graph, data tables, diagrams, and symbols.

**A new sound-generating device is being tested that will send waves through different types of materials. It is tested on a liquid, a solid, and a gas. The device is tested three times on each material. The time it takes for the wave to return is recorded for each test.**

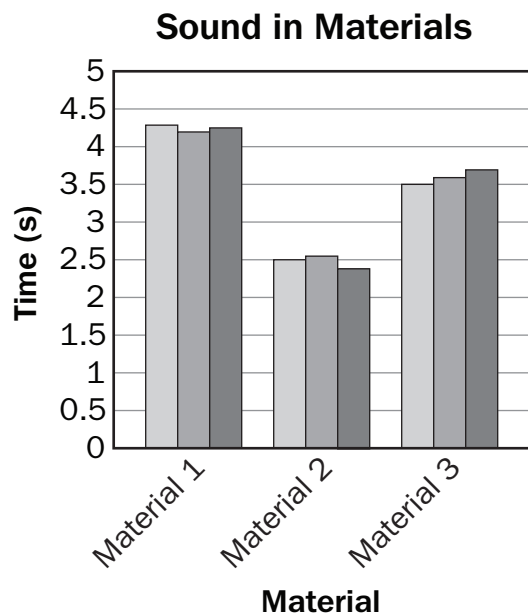

**Which statement BEST identifies each material based on the time it takes for the sound wave to travel through the material?**

- A. Material 1 is a gas; Material 2 is a liquid; Material 3 is a solid.
- B. Material 1 is a liquid; Material 2 is a solid; Material 3 is a gas.
- C. Material 1 is a solid; Material 2 is a gas; Material 3 is a liquid.
- D. Material 1 is a gas; Material 2 is a solid; Material 3 is a liquid.

**Correct Answer:** D

**Explanation of Correct Answer:** The correct answer is choice (D) Material 1 is a gas; Material 2 is a solid; Material 3 is a liquid. Wave speed is dependent on the medium in which it is traveling. Sound generally travels fastest through solids and slowest through gases. In the graph, Material 2 has the fastest times and therefore is a solid. Material 1 has the slowest times in the graph and is a gas. Material 3 has an intermediate set of times and is a liquid. Choice (A) is incorrect because Material 1 is a gas, but Material 2 is not a liquid and Material 3 is not a solid. Choice (B) is incorrect because Material 2 is a solid, but Material 1 is not a liquid and Material 3 is not a gas. Choice (C) is incorrect because Material 3 is a liquid, but Material 1 is not a solid and Material 2 is not a gas.

## SCIENCE CONTENT DESCRIPTION AND ADDITIONAL SAMPLE ITEMS

In this section, you will find information about what to study in order to prepare for the Grade 8 Science EOG assessment. This includes main ideas and important vocabulary words. This section also contains practice questions, with an explanation of the correct answers, and activities that you can do with your classmates or family to prepare for the test.

**All example and sample items contained in this guide are the property of the Georgia Department of Education.**

### CONTENT DESCRIPTION

- Explain and demonstrate the Laws of Conservation of Energy and Conservation of Matter
- Explain heat transfer through matter and space
- Determine the relationship between force and motion
- Describe physical and chemical properties and physical and chemical changes of matter
- Explain how elements can be organized according to their properties
- Recognize the differences between pure substances and mixtures
- Investigate relationships between force, mass, and the motion (acceleration and velocity) of objects
- Describe the effect of simple machines on work
- Explore the wave nature of sound and electromagnetic radiation
- Explain the behavior of light and sound in terms of everyday experiences
- Identify gravity, electricity, and magnetism as forces acting in nature
- Demonstrate the advantages and disadvantages of series and parallel circuits and how they transfer energy
- Describe the relationship between electric currents and magnets

### CHARACTERISTICS OF SCIENCE STANDARDS

- Recognize the value of hypothesis to construct possible explanations of natural phenomena
- Use standard safety practices while conducting laboratory and field investigations
- Analyze scientific data to interpret results that support explanations
- Apply appropriate technology to collect and store scientific information
- Use models to represent natural phenomena and support scientific explanations
- Communicate information in written and oral forms
- Organize information in different representations (i.e., tables, charts, and graphs) and identify the relationships they reveal
- Question claims and arguments based on scientific evidence
- Recognize that scientific investigations usually involve collecting evidence, reasoning, devising hypotheses, and formulating explanations to make sense of collected evidence
- Understand how science knowledge grows and changes

## Unit 1: Sports

This unit will focus on developing a conceptual understanding of the nature of matter; the relationship between force, mass, and the motion of objects; and energy transformations that occur during sports activities. You will develop an understanding that all objects (e.g., sports equipment, uniforms, etc.) and substances in the natural world are composed of matter that is influenced by forces. You will explore the relationship between velocity and acceleration through graphical representations of the motion of objects. You will gain a qualitative understanding of the Universal Laws of Motion through scenarios in which forces act through direct physical contact between objects as well as examples in which forces act on objects at a distance (via gravitational force). Finally, you will apply your understanding of the Universal Laws of Motion to predict and explain how simple machines make work easier.

### KEY TERMS

**Substance** is matter of any form that cannot be broken down into separate elements by physical means but can be broken down using chemical changes. (S8P1b)

**Elements** are pure chemical substances that are made up of one type of atom. **Atoms** are the smallest unit of matter that defines the chemical element. A **molecule** is made of two or more atoms that are held together by their chemical bonds. Molecules can be made of the same element or two different elements. Water is a molecule that is made up of two atoms of hydrogen and one atom of oxygen. (S8P1f)

A **compound** is a pure chemical substance that is made up of two or more different elements. A molecule of salt is made up of one atom of sodium and one atom of chlorine. (S8P1b)

A **mixture** is something that contains two or more substances that are not combined chemically. Salted popcorn is an example of a mixture. (S8P1b)

The **Law of Conservation of Energy** states that the total amount of energy in a system cannot change unless energy enters or leaves that system by some form and that energy cannot be created or destroyed. Energy can only change forms. An **energy transformation** refers to the changing of energy from one form to another. (S8P2a)

**Potential energy** is the energy stored in an object due to its position. The energy stored in a ball sitting at the top of a ramp is all potential energy. In the case of the ball, gravity is pulling down on the ball. Although the ball is not rolling down the hill, it has potential energy due to the pull of gravity. (S8P2b)

**Kinetic energy** is the energy of **motion**. As the ball starts to roll down the ramp, the potential energy of the ball transforms into kinetic energy. The energy in the system is converted from potential energy to kinetic energy. (S8P2b)

**Velocity** is a quantity that measures the rate of an object changing its position. If you take a step forward and then a step back to the original position, the velocity is unchanged because the motion did not result in a change in your position. If you take two steps forward, your position has changed. Your velocity is “two steps forward.” Velocity always describes a distance and a direction. (S8P3a)

**Acceleration** is a quantity that measures the rate at which an object changes its velocity. People often talk about an object decelerating when the object slows down. An object that slows down is actually experiencing a negative acceleration. This means the rate of change is a negative value. An object can have a velocity but not acceleration if it is moving at a constant velocity. Let's say you take a car trip that takes one hour. The velocity of the car is 40 miles east. The average speed of the trip is 40 miles per hour (mph). In the middle of the trip, the car accelerated to 50 mph for 10 minutes and then accelerated to 30 mph for 10 minutes. (S8P3a)

A **force** is a push or pull on an object. Force can be the result of contact, such as when you push a book across your desk. Forces can also result when objects are not in contact with each other. When you use one magnet to push another magnet, there is a force that acts on the magnets although the magnets are not in contact. (S8P3b)

When two or more forces act on an object but the object's velocity does not change, it is said the object is being acted on by **balanced forces**. A book on your desk that is not moving is said to be **stationary**. The book is said to be at **rest** in relation to the desk. Gravity is acting to pull the book down. The desk pushes up against the book, and the book is at rest in relation to the desk. (S8P3b)

An accelerating object is being acted on by **unbalanced forces**. When you push your book across your desk, you are applying force to one side of the book. The force of friction acts on the book in the opposite direction that it is moving, reducing the speed at which the book moves. Because the book still begins to move in the direction you are pushing it, we say that these forces are unbalanced. (S8P3b)

**Friction** is the force that resists motion between two surfaces. When you rub your hands together, friction creates heat. (S8P3b)

**Inertia** is the resistance to any change in the state of motion of any physical object. All matter has inertia until unbalanced forces act on it and cause it to move. (S8P3b)

**Matter** is anything that has mass and occupies space. Matter can be found in several states (solid, liquid, gas, plasma, etc.). (S8P1c)

**Mass** is the total amount of matter of an object. Mass is a numerical measure of its inertia. The mass of an object does not change regardless of where the object is located. (S8P3b)

**Weight** is a measure of the force of gravity pulling on a mass. If you could weigh yourself at sea level and then could instantly be in Denver (which is a mile above sea level) and weigh yourself again, you would have two different weights. The force of gravity is less the farther away it is from Earth's center, so the force of gravity would pull less on your mass in Denver than it would at sea level. (S8P3b, S8P5a)

**Gravity** is the force of attraction that exists between any two or more masses. Gravity can refer to the force that Earth exerts on everything. Because the force of gravity for each object is related to the mass of the object, larger objects, such as Earth, exert a greater gravitational force than objects that have less mass, such as a human. (S8P3b, S8P5a)

In physics, **work** is done when a force causes an object to move in the direction of the force. If you push on a building, you might start to sweat and breathe hard, but you have done no work until the building moves in the direction of your push. (S8P3c)

**Simple machines** are devices that change the direction or amount of force used to do work. There are six simple machines (lever, inclined plane, pulley, wedge, screw, and wheel and axle). (S8P3c)

The **lever** is a simple machine made up of a straight beam and a fulcrum, a point that the beam pivots on. Levers change the amount of force required to move an object. A seesaw is an example of a lever. (S8P3c)

An **inclined plane** is a simple machine that uses a flat surface to help raise or lower a load. Inclined planes spread the amount of force required to lift a load over a distance. Wheelchair ramps are an example of an inclined plane. (S8P3c)

A **wedge** is a simple machine made up of one or two inclined planes. Wedges change the direction of a force from a straight line to perpendicular to that force. A wedged doorstop is an example of a wedge. The door tries to close. By putting a wedged doorstop between the door and the floor, the force of the door closing is turned 90 degrees and applied to the floor. The floor then resists the door closing. Knives are also an example of a wedge. (S8P3c)

A **screw** is a simple machine that can be thought of as an inclined plane wrapped around an axle. Because of this, the force required to do something is spread out over a longer distance. (S8P3c)

The **wheel and axle** is a simple machine made up of a wheel and an attached axle. The wheel and axle transfers the force from the wheel to the axle. (S8P3c)

A **pulley** is a simple machine made up of a rope or chain that is led around a wheel and axle. Pulleys change the direction of a force. Certain pulley combinations can also change the amount of force required to move an object. (S8P3c)

### **Important Tips**

- ✍ When thinking of energy transforming from one form to another, remember that in most cases, it is not a matter of one form of energy being transformed only into another form of energy. When you rub your hands together, the kinetic energy of your hands is transformed by friction into heat energy. You can also hear your hands rubbing together, which is the result of the friction converting some of the kinetic energy into sound energy. (S8P2a)
- ✍ When comparing mass and weight, recall that mass does not depend on location or gravitational forces. When objects travel to space or to the moon, their mass does not change, but their weight will change as the forces of gravity change on them throughout the entire trip. (S8P3)

## Sample Items 1–4

### Item 1

A teacher boils clear liquids in two beakers. Afterward, Beaker A has a white powder left in it, but Beaker B is empty. The teacher states that one beaker contained only water while the other beaker contained salt water. Student 1 reaches the conclusion that Beaker A contained a mixture whereas Beaker B contained a pure substance. Student 2 reaches the conclusion that Beaker A held only water while Beaker B held salt water.

Which student’s conclusion is **MOST LIKELY** correct?

- A. Both students are correct.
- B. Both students are incorrect.
- C. Student 1 is correct, while Student 2 is incorrect.
- D. Student 1 is incorrect, while Student 2 is correct.

### Item 2

A soccer ball is thrown into the game from the sidelines.

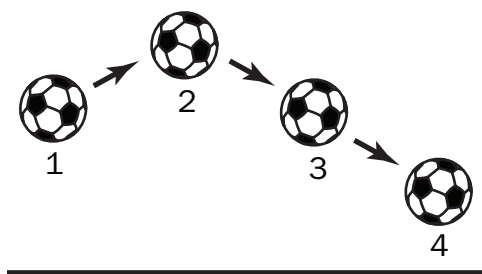

Which statement **BEST** describes the ball’s travel in terms of potential and kinetic energy?

- A. The ball has maximum kinetic energy at Point 1 and maximum potential energy at Point 4.
- B. The ball has maximum potential energy at Point 1 and maximum kinetic energy at Point 3.
- C. The ball has maximum potential energy at Point 2 and maximum kinetic energy at Point 4.
- D. The ball has maximum kinetic energy at Point 2 and maximum potential energy at Point 3.

### Item 3

**A student plans an experiment to test the Law of Conservation of Energy. The student sets up a pendulum and hypothesizes that the pendulum will not stop. The student finds that the pendulum eventually slows down and stops.**

**Explain these results in terms of the Law of Conservation of Energy.**

- A. The pendulum stopped because air resistance slowed the pendulum, and according to the Law of Conservation of Energy, energy was destroyed.
- B. The pendulum stopped because there was not enough kinetic energy, and according to the Law of Conservation of Energy, the energy was destroyed.
- C. The pendulum stopped due to friction, and according to the Law of Conservation of Energy, no energy is lost, just changed from potential energy to thermal energy.
- D. The pendulum stopped due to gravity, and according to the Law of Conservation of Energy, no energy is lost, just changed from gravitational energy to potential energy.

### Item 4

**Two equal forces act at the same time on the same stationary object, but in opposite directions.**

**Which statement describes the object's resulting motion?**

- A. The object will accelerate.
- B. The object will change direction.
- C. The object will remain stationary.
- D. The object will move at a constant speed.



## Unit 2: Food and Cooking

In this unit, you will develop a conceptual understanding of the nature of matter, forms of energy, and how energy is transformed from one form to another. You will learn how these ideas connect to phenomena that occur during cooking. You will understand that in a chemical reaction, matter can neither be created nor destroyed, only transformed. You will learn about the characteristics of matter (i.e., physical and chemical properties) that are useful to classify and differentiate substances.

### KEY TERMS

**Atoms** are the smallest unit of matter that defines the chemical element. **Elements** are pure chemical substances that are made up of one type of atom. A **molecule** is made of two or more atoms that are held together by their chemical bonds. Molecules can be made of the same element or more than one element. Water is a molecule that is made up of two atoms of hydrogen and one atom of oxygen. (S8P1a, b)

The **Periodic Table of Elements** is a table arranging all the known elements into groups with common properties. This arrangement also demonstrates trends based on those properties.

### Periodic Table of Elements

1 1 H Hydrogen																	18 2 He Helium																	
3 Li Lithium	4 Be Beryllium											5 B Boron	6 C Carbon	7 N Nitrogen	8 O Oxygen	9 F Fluorine	10 Ne Neon																	
11 Na Sodium	12 Mg Magnesium											13 Al Aluminum	14 Si Silicon	15 P Phosphorus	16 S Sulfur	17 Cl Chlorine	18 Ar Argon																	
19 K Potassium	20 Ca Calcium	21 Sc Scandium	22 Ti Titanium	23 V Vanadium	24 Cr Chromium	25 Mn Manganese	26 Fe Iron	27 Co Cobalt	28 Ni Nickel	29 Cu Copper	30 Zn Zinc	31 Ga Gallium	32 Ge Germanium	33 As Arsenic	34 Se Selenium	35 Br Bromine	36 Kr Krypton																	
37 Rb Rubidium	38 Sr Strontium	39 Y Yttrium	40 Zr Zirconium	41 Nb Niobium	42 Mo Molybdenum	43 Tc Technetium	44 Ru Ruthenium	45 Rh Rhodium	46 Pd Palladium	47 Ag Silver	48 Cd Cadmium	49 In Indium	50 Sn Tin	51 Sb Antimony	52 Te Tellurium	53 I Iodine	54 Xe Xenon																	
55 Cs Cesium	56 Ba Barium											72 Hf Hafnium	73 Ta Tantalum	74 W Tungsten	75 Re Rhenium	76 Os Osmium	77 Ir Iridium	78 Pt Platinum	79 Au Gold	80 Hg Mercury	81 Tl Thallium	82 Pb Lead	83 Bi Bismuth	84 Po Polonium	85 At Astatine	86 Rn Radon								
87 Fr Francium	88 Ra Radium											104 Rf Rutherfordium	105 Db Dubnium	106 Sg Seaborgium	107 Bh Bohrium	108 Hs Hassium	109 Mt Meitnerium	110 Ds Darmstadtium	111 Rg Roentgenium	112 Cn Copernicium	113 Uut Ununtrium	114 Fl Flerovium	115 Uup Ununpentium	116 Lv Livermorium	117 Uus Ununseptium	118 Uuo Ununoctium								
																		57 La Lanthanum	58 Ce Cerium	59 Pr Praseodymium	60 Nd Neodymium	61 Pm Promethium	62 Sm Samarium	63 Eu Europium	64 Gd Gadolinium	65 Tb Terbium	66 Dy Dysprosium	67 Ho Holmium	68 Er Erbium	69 Tm Thulium	70 Yb Ytterbium	71 Lu Lutetium		
																		89 Ac Actinium	90 Th Thorium	91 Pa Protactinium	92 U Uranium	93 Np Neptunium	94 Pu Plutonium	95 Am Americium	96 Cm Curium	97 Bk Berkelium	98 Cf Californium	99 Es Einsteinium	100 Fm Fermium	101 Md Mendelevium	102 No Nobelium	103 Lr Lawrencium		

**Substance** is matter of any form that cannot be broken down into separate elements by physical means but can be broken down using chemical changes. (S8P1b)

A **compound** is a pure chemical substance that is made up of two or more different elements. A molecule of salt is made up of one atom of sodium and one atom of chlorine. (S8P1b)

**Matter** is anything that has mass and occupies space. Matter can be found in several states (solid, liquid, gas, plasma, etc.). (S8P1c)

**The states of matter** are the different forms that matter can be found in. Water is a **liquid**, the state of matter that has a definite volume but no fixed shape. When water is ice, it is a **solid**. Solids have a definite shape and volume. Their shape and volume cannot be easily changed. When water is steam, or water vapor, it is a **gas**. Gases have no definite shape and take the shape of their container. **Plasma** is gas that is charged. Plasma conducts electricity easily. Stars and neon lights are examples of plasma. Plasma is different from the other states of matter in that it is a high-energy state of matter. (S8P1)

A **mixture** is something that contains two or more substances that are not combined chemically. Salted popcorn is an example of a mixture. (S8P1b)

**Physical properties** are any properties that are measurable and can be observed. Physical properties can be determined without changing the chemical properties of an object. Color, hardness, area, length, strength, and temperature are some examples of physical properties. (S8P1d, f)

**Mass** is the total amount of matter of an object. Mass is a numerical measure of the object's inertia. The mass of an object does not change regardless of where the object is located.

**Volume** is the amount of space that an object or substance occupies. Volume is a physical property.

**Density** is the physical property that describes how tightly matter is put together. A pure element, such as gold, will have a characteristic density and mass. (S8P1f)

**Boiling point** is the physical property that describes the temperature at which a substance will change from a liquid to a gas. Water boils at 100°C (212°F). (S8P1f)

**Melting point** is the physical property that describes the temperature at which a solid will become a liquid. Ice, a solid, will change into liquid water at 0°C (32°F). This is the melting point of water. (S8P1f)

**Chemical properties** are any properties that can only be measured by chemically changing an object. Paper starts to burn at around 450°F. At this temperature the paper combines with oxygen in the air and new substances are formed. (S8P1d)

**Combustibility** is the chemical property of how easily a substance will set on fire. (S8P1d)

**Reactivity** is the chemical property of the capacity of an atom or molecule to go through a chemical reaction with another atom or molecule. Sodium is a very reactive metal. Sodium reacts rapidly and energetically with other substances. Gold is a metal that is not very reactive. It won't tarnish from oxygen or water. (S8P1d)

A **physical change** happens when matter has a change in its physical properties but not its chemical properties. For example, salt can be dissolved in water, but if the water evaporates, the salt is still there. (S8P1e)

A **chemical change** happens when matter breaks down into two or more substances OR when more than one substance is combined to form a new substance. Hydrogen peroxide forming bubbles on its own is an example of matter breaking down into two substances. Vinegar and baking soda turning into bubbling foam is an example of two substances combining to create other substances. (S8P1e)

A **chemical reaction** is a process where two or more substances combine chemically in some way to form one or more other substances. When iron is combined with air and water, the iron is slowly converted into rust. (S8P1e)

A **precipitate** is a solid that is formed by a chemical reaction or by diffusion in a solid. Precipitates can form in a solution or inside another solid. (S8P1e)

The **Law of Conservation of Matter** states that the total amount of matter in a system cannot be created or destroyed. When a piece of paper burns, it becomes ash, water vapor, and carbon dioxide. If you could collect up the ash, water vapor, and carbon dioxide and mass it, you would find that it had the same mass as the paper before it was burnt. (S8P1g)

The **Law of Conservation of Energy** states that the total amount of energy in a system cannot change and that energy cannot be created or destroyed. Energy can only change forms. An energy transformation refers to the changing of energy from one form to another. (S8P2a)

**Conduction** is the movement of heat through an object or from one object to another when they are touching. In conduction, thermal energy is transferred between atoms when they collide with each other. Thermal energy moves from warmer areas, those with higher energy, to cooler areas, those with less energy. This is why ice in a glass of water melts on a warm day. The thermal energy flows toward the ice and the energy turns the ice into water. Warm air molecules collide with the molecules of the glass container and transfer thermal energy to them. The molecules in the container then pass the thermal energy between themselves by direct contact. Finally, the energy is transferred to the water and ice by the water molecules coming in contact with both. (S8P2d)

**Convection** is the movement of heat through fluids and gases. In convection, thermal energy is transferred due to differences in density caused by temperature variations. When you heat a pot of soup, the liquid becomes warm through convection. As the liquid at the bottom of the pot becomes warmer, its density decreases. The increased thermal energy causes the molecules to move faster, which spaces them farther apart, which increases the volume and thus decreases the density. The change in density causes the warm liquid to rise to the top of the soup. As the mass of warmer soup rises, it comes in contact with cooler soup above it and passes the thermal energy to it. The motion of the warmer mass is convection. (S8P2d)

Heat can also move by means of **radiation**. Thermal radiation does not require any form of matter to move through, as conduction and convection require. Thermal radiation energy moves via electromagnetic waves. Because of this, thermal radiation moves very fast. (S8P2d)

***Important Tip***

 The movement of particles within the different states of matter can vary greatly. Particles in solids are packed together very tightly, and they do not move around easily. This is why solids tend to be hard. Particles in a liquid move around and are packed loosely. Particles in gases move in all sorts of directions, and the particles are spread very far apart. (S8P1c)

---

## Sample Items 5–8

### Item 5

You inflate a balloon with helium. The balloon feels stiff.

Which properties of a gas **BEST** explain this observation?

- A. The particles are moving quickly and are far apart.
- B. The particles are closely packed and vibrate in place.
- C. The particles slide past each other and are close together.
- D. The particles are closely packed and are moving very quickly.

### Item 6

Study the list of processes below.

1. A pencil is broken in half.
2. A nail is left outside and rusts.
3. Baking soda and vinegar are used in a model volcano.
4. Ice left on the counter melts.
5. Salt is combined with water to make a saltwater solution.
6. Milk that is left out of the refrigerator sours.

Which of these processes would produce a chemical change?

- A. 2, 3, 6
- B. 1, 4, 6
- C. 1, 4, 5
- D. 2, 3, 5

**Item 7**

A science teacher places a sealed microwave bag of popcorn on a balance and measures its mass.

She microwaves the popcorn and finds the mass again before opening the bag. The masses are nearly the same.

Which scientific law does this BEST demonstrate?

- A. Law of Cause and Effect
- B. Law of Thermodynamics
- C. Law of Conservation of Volume
- D. Law of Conservation of Matter

**Item 8**

A lab group places an aquarium filled with warm water on a working hot plate. A cup of blue ice with holes in the bottom is floating at one end of the aquarium. Red dye is dropped into the other end of the aquarium. The group then observes that the red dye starts to spread out from one end of the aquarium to the other. They also observe that at the same time, blue water from the cup of ice starts moving across the bottom of the aquarium. Over time, the red dye moves downward and the blue dye moves upward in a circular pattern. One student suggests that this shows how cold from the ice conducts the water around the aquarium.

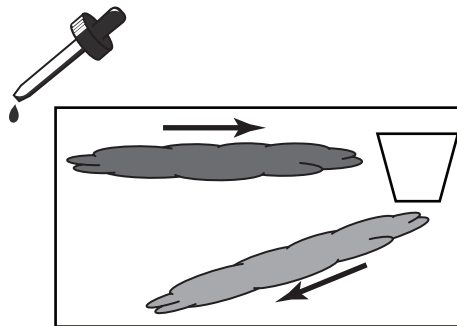

Which statement is the BEST response to the student's theory?

- A. This shows how different colors of dyes cause water to move in different directions.
- B. This shows how the warm red water radiates heat toward the cool blue water, causing it to sink.
- C. This shows how convection currents move as the water warms and cools, causing it to rise or sink.
- D. This shows how the cold ice cubes in the cup transfer heat to the warm red water, causing it to sink.

## Unit 3: Energy in Our Life

In this unit, you will develop an understanding that energy exists in many forms. You will learn that in a closed system energy can be transferred and transformed, but the total amount of energy available is always the same—it is conserved. You will also learn about two of the four main forces in the universe: gravitational and electromagnetic forces. You'll determine how these forces influence the motion of objects and are responsible for the work that a system does or for the work that is done on a system.

### KEY TERMS

The **Law of Conservation of Energy** states that the total amount of energy in a system cannot change and that energy cannot be created or destroyed. Energy can only change forms. An **energy transformation** refers to the changing of energy from one form to another. (S8P2a)

**Potential energy** is the energy stored in an object due to its position. In the case of a ball at the top of an inclined plane, gravity is pulling down on the ball. Although the ball is not rolling down the inclined plane, it has potential energy due to the pull of gravity. (S8P2b)

**Kinetic energy** is the energy of **motion**. As the ball starts to roll down the inclined plane, the potential energy of the ball transforms into kinetic energy. The energy in the system is converted from potential energy to kinetic energy. (S8P2b, d)

**Mechanical energy** is the total of all the potential energy and kinetic energy in an object. Mechanical energy is the energy of position and motion of an object. (S8Pc)

**Thermal energy** is the flow of energy from an object that has a higher temperature to one that has a lower temperature. The kinetic energy (movement) of particles in a warm object is higher than the kinetic energy of particles in a cool object. Some of the kinetic energy flows from the warm object to the cool object, and the temperatures of the two objects even out. When you go outside on a cold day without a jacket on, the heat energy in your body starts to flow to the cooler air. (S8Pc, d)

**Conduction** is the movement of heat through an object or from one object to another when they are touching. In conduction, thermal energy is transferred between atoms when they collide with each other. Thermal energy moves from warmer areas, those with higher energy, to cooler areas, those with less energy. This is why ice in a glass of water melts on a warm day. The thermal energy flows toward the ice and the energy turns the ice into water. Warm air molecules collide with the molecules of the glass container and transfer thermal energy to them. The molecules in the container then pass the thermal energy between themselves by direct contact. Finally, the energy is transferred to the water and ice by the water molecules coming in contact with both. (S8P2d)

**Convection** is the movement of heat through fluids and gases. In convection, thermal energy is transferred due to differences in density caused by temperature variations. When you heat a pot of soup, the liquid becomes warm through convection. As the liquid at the bottom of the pot becomes warmer, its density decreases. The increased thermal energy causes the molecules to move faster, which spaces them farther apart, which increases the volume and thus decreases the density. The change in density causes the warm liquid to rise to the top of the soup. As the mass of warmer soup rises, it comes in contact with cooler soup above it and passes the thermal energy to it. The motion of the warmer mass is convection. (S8P2d)

Heat can also move by means of **radiation**. Thermal radiation does not require any form of matter to move through, as conduction and convection require. Thermal radiation energy moves via electromagnetic waves. Because of this, thermal radiation moves very fast. (S8P2d)

**Electric energy** is the energy of electrons moving through a conductor. Electricity is the name we give to the motion of electrons along the path formed by a conductor. (S8P2a)

**Magnetic energy** is produced when magnetic fields are generated. (S8P2a)

Gravity also refers to the **gravitational force** every object exerts on every other object. Because the force of gravity for each object is related to the mass of the object, larger objects, such as Earth, exert a greater gravitational force than objects that have less mass, such as a human. (S8P5a)

**Mass** is the total amount of matter of an object. Mass is a numerical measure of the object's inertia. The mass of an object does not change regardless of where the object is located. (S8P5a)

A **force** is a push or pull on an object. A force can be the result of contact, such as when you push a book across your desk. Forces can also result when objects are not in contact with each other. When you use one magnet to push another magnet, there is a force that acts on the magnets although the magnets are not in contact. (S8P3b)

When two or more forces act on an object but the object's velocity does not change, it is said the object is being acted on by **balanced forces**. A book on your desk that is not moving is said to be **stationary**. The book is said to be at **rest** in relation to the desk. Gravity is acting to pull the book down. The desk pushes up against the book and the book is at rest in relation to the desk. (S8P3b)

An accelerating object is being acted on by **unbalanced forces**. When you push your book across your desk, you are applying force to one side of the book. The force of friction acts on the book in the opposite direction that it is moving, reducing the speed at which the book moves. Because the book still begins to move in the direction you are pushing it, we say that these forces are unbalanced. (S8P3b)

To make an **electric circuit** you need at least a power source and a path for the electric current to flow through. You can add other devices like resistors, such as a light bulb, along the path. You can also add a switch to start and stop the flow of an electric current to the circuit. (S8P5b)

**Series circuits** are electric circuits where the devices powered by the circuit are connected one after the other. The electrons can only flow in one direction. A series circuit is like a flight of stairs. If one step of the stairs is missing, you cannot move to the next step. In a series circuit, if one device fails, electricity stops flowing through the circuit. (S8P5b)

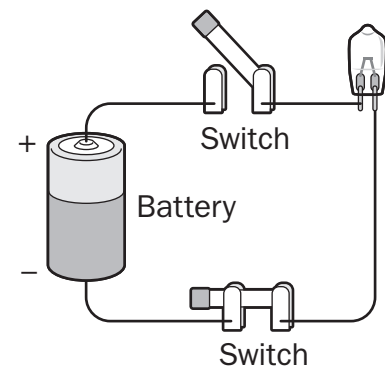

**Series Circuit**



**Parallel circuits** are electric circuits where the devices powered by the circuits have multiple paths for the electrons to flow. Think of a ladder. The legs of the ladder are the path the electricity flows along. Each rung is a device that draws electricity from the legs. If one rung is lost, the electricity would still be able to flow through the circuit. (S8P5b)

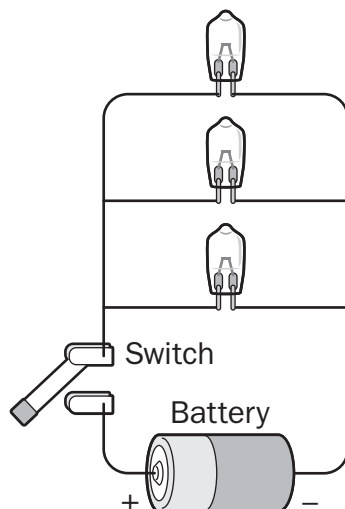

**Parallel Circuit**

**Electric current** is the flow of an **electric charge** through a conductor. When electric currents move through a conductor, they create heat and magnetic fields. Lightning, static electricity, and the movement of electricity in power lines are examples of electric currents. (S8P5b)

**Electric force** is the force of attraction between two electrically charged objects. When you use a balloon to pick up pieces of paper, the electric force between the balloon and pieces of paper is great enough to pick up the pieces of paper. Objects cling to each other when there is enough electric force to cause them to cling together. (S8P5b)

**Electrons** are particles found in atoms. Electrons carry a negative electric charge. When electricity flows through a wire, electrons bump into atoms. The electron that hits the atom knocks one electron off the atom and takes its place. The electron that was just knocked off its atom then repeats the process. The electricity that is found at the other end of a circuit consists of the electrons that have been repeatedly knocked from one atom to another. (S8P5b)

Magnetic materials have what is known as magnetic domains—they are sort of like pieces of a big puzzle, as shown in the illustration of magnetized material below. The two poles of a magnet result when these magnetic domains align in such a way that they point in the same direction. If you cut a magnet in half, the domains of each half will still line up so that the two new magnets each have a north pole and a south pole. In an object that is not magnetized, the domains lie in many different directions (as shown in the illustration below) and mostly cancel each other out. (S8P5c)

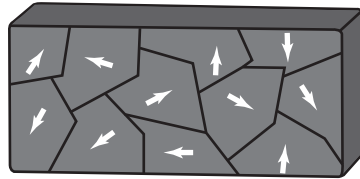

**Not Magnetized**

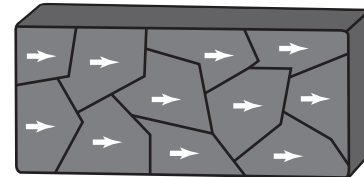

**Magnetized**

An **electromagnet** is created when a wire is coiled and an electric current flows through it. Generally, electromagnets have a metal core that helps to increase the strength of the electromagnet. Magnetic force is created by the movement of electrical charges through a wire. A magnetic field is created around the wire and this magnetic field lines up the domains in the core, turning the core into a temporary magnet. When the electric current is turned off, the magnetic field quickly fades. You can make an electromagnet using a circuit with a battery, switch, and wire wrapped around a nail. (S8P5c)

### **Important Tip**

 In electric circuits, the electrons flow from the negative pole of the battery, where there is an excess of electrons, to the positive pole of the battery, where there is a deficit of electrons. An easy way to remember this is by looking at the symbols for each pole. The negative pole (shown by a  $-$ ) looks like an arrow. It is shooting away from pole. The positive pole (shown by a  $+$ ) looks like the addition symbol. It is trying to add electrons to its pole. (S8P5c)

## Sample Items 9–12

### Item 9

What energy transformation causes the blades of an electric fan to move when an electric fan is turned on?

- A. sound to motion
- B. heat to electricity
- C. electricity to motion
- D. motion to electricity

### Item 10

Study the circuit diagram.

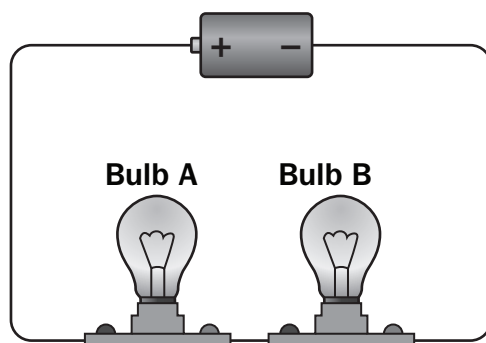

If Bulb B burns out, what will happen to Bulb A?

- A. It will get brighter.
- B. It will get dimmer.
- C. It will stop working.
- D. It will stay the same.

**Item 11**

A student is investigating how a compass works. The student places several compasses around a wire. The compasses are 5 centimeters away from each other.

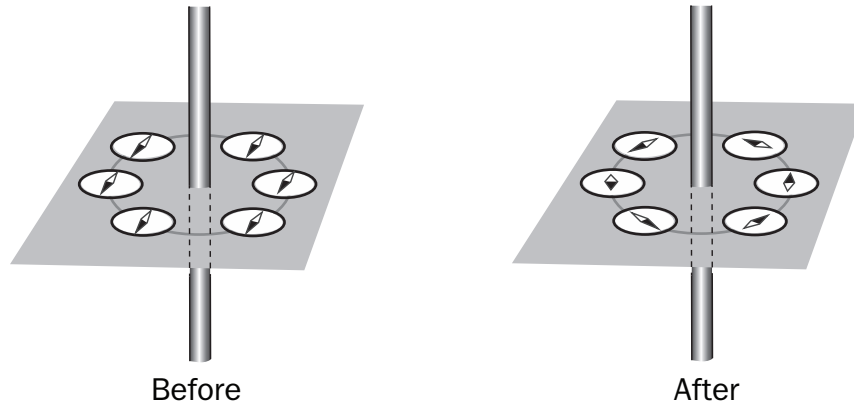

**What can the student do to cause the needles of the compasses to change as shown?**

- A. move the wire back and forth
- B. run electricity through the wire
- C. bend the wire around the compasses
- D. bring the compasses closer to the wire

**Item 12**

A student is investigating the motion of a pendulum. The student holds the bob in Position A and then releases it.

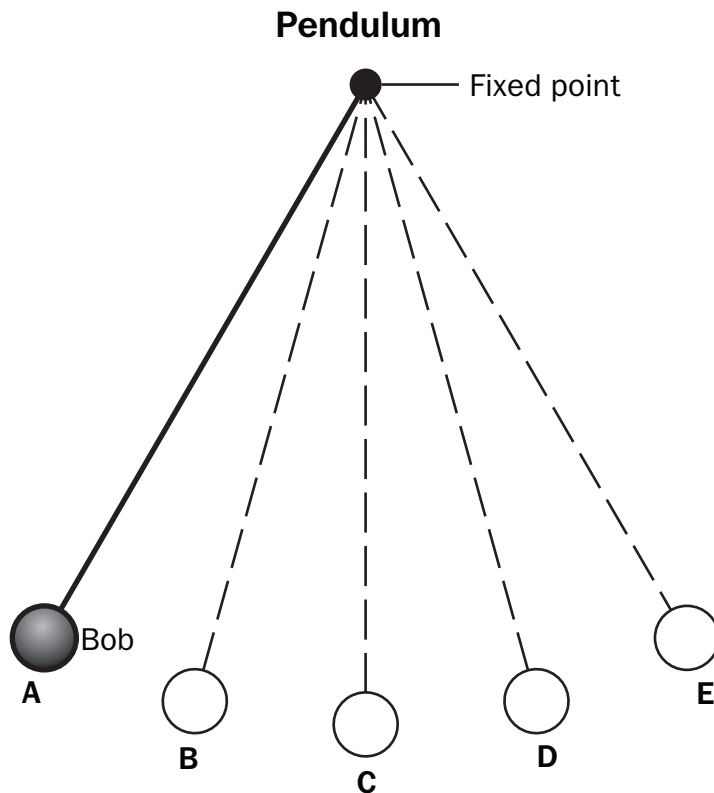

Which statement is correct about the energy of the bob?

- A. The kinetic energy of the bob is greatest in Position A.
- B. The potential energy of the bob is greatest in Position C.
- C. Kinetic energy changes to potential energy as the bob moves from Position D to Position E.
- D. Potential energy changes to kinetic energy as the bob moves from Position C to Position D.

## Unit 4: Light and Sound Show

In this unit, you will acquire a conceptual understanding of the nature of sound and electromagnetic radiation. You will also learn to apply the Law of Conservation of Energy to explain how energy is transferred as waves propagate. You will study how sound behaves in the presence of different obstacles and how light is manipulated by positioning mirrors and lenses in its path.

### KEY TERMS

**Waves** are constant fluctuations that can travel through matter or space. When you throw a rock in a puddle, the water forms waves that move outward from the place where the rock hit the water. Waves can move through solids, liquids, gases, and empty space. (S8P4a)

**Frequency** is the number of vibrations per a unit of time that a wave possesses. If you counted the number of wave peaks from throwing the rock in a puddle that occurred in a minute, you could determine the wavelength of that vibration. (S8P4a)

**Wavelengths** are the distance from one peak of a wave to the next peak of the wave. (S8P4a)

**Amplitude** is the property of a wave that describes half the distance between the height of the peak of a wave and the trough (the bottom) of a wave. In a surf wave, the amplitude represents the amount of water displaced, which can be very large. (S8P4a)

The **characteristics of a wave** are determined by the wavelength, frequency, and amplitude of the wave. (S8P4a)

**Electromagnetic radiation** is a term that is used to describe radio waves, microwaves, infrared radiation, visible light, ultraviolet radiation, X-rays, and gamma rays. Radio waves have the smallest frequency and the longest wavelength. Gamma rays are at the other end of the electromagnetic radiation spectrum. Gamma rays have the largest frequency and the shortest wavelength. (S8P4a)

**Electromagnetic waves** do not require a medium to move through. Electromagnetic waves transport energy that is stored in the electric and magnetic field. (S8P4a)

Mechanical waves are caused by a disturbance or vibration that causes the molecules in matter to bump into each other and transfer the energy from one molecule to the next in a set direction. Matter is required as a **medium** for the waves to move through, so mechanical waves cannot occur in the vacuum of space. (S8P4a)

**Sound** is a mechanical wave that can be heard as it moves through a medium, such as air, and displaces the air, creating zones of high and low pressure. When fireworks go off on the Fourth of July, you can hear the sound. With some of the larger fireworks, you can also feel the air as the pressure from the firework exploding pushes the air away from the firework. (S8P4e)

When people refer to the **pitch** of a sound, they are referring to the sensation of the frequency of the wave. The **intensity** of a sound is related to the amplitude of the wave. (S8P4f)

When people refer to **light**, they are usually referring to the visible light they can see. Light is not considered matter and has no mass. The behavior of light can be explained by the introduction of a massless particle called a photon or by studying the way that electromagnetic waves interact with matter. (S8P4b)

There are several processes that light can go through as it encounters matter.

**Reflection** occurs when light bounces off a medium. When light is reflected, not all the light is reflected. **Refraction** occurs when light moves through a medium and bends as the medium slows down the light as it moves through the medium. When you look through a glass of water and an object behind the glass appears to change shape, the light reflected by that object has been refracted by the glass. **Diffraction** occurs when light encounters an obstacle and slightly bends as it passes around the object. If you hold a CD and see the colors of the rainbow, this is the light being diffracted by the surface of the CD. **Absorption** occurs when light strikes a surface and the energy of the photon is taken up by the matter. An object lying in the sun will warm up as the sunlight transforms into heat energy. (S8P4b)

When the human eye sees **colors**, it is seeing the parts of the spectrum of light that are reflected from an object. A blue object reflects the wavelengths of light that we see as blue. (S8P4c)

### **Important Tip**

✍ The way waves travel is known as wave propagation. As waves propagate, some of the energy is transferred. When light travels through a glass of water, it slows down and is refracted. Some of the energy that is lost—and that causes the light to slow down—is transferred into the water and glass as thermal energy. (S8P4a)

## Sample Items 13–16

### Item 13

As a race car drives away from an observer, the observer notes that the sound from the car gets quieter and the pitch lowers.

Which statement **BEST** describes how the sound wave changes as the race car drives away?

- A. The frequency increases and the amplitude increases.
- B. The frequency increases and the amplitude decreases.
- C. The frequency decreases and the amplitude increases.
- D. The frequency decreases and the amplitude decreases.

### Item 14

An advertisement claims that a new type of cotton cloth looks red because of the way the cloth is woven and not because of the dye used on the cloth.

Which statement **BEST** explains why the chemical dye is responsible for the red appearance of the cloth?

- A. The chemical absorbs the light from the visible spectrum except for red that is reflected to the eye.
- B. The chemical absorbs all the red light from the visible spectrum that is reflected to the eye.
- C. The light is refracted and the longest wavelength shows through the one that is red.
- D. The chemical reaction produces a red light that is emitted, so the cloth looks red.



**Item 15**

Which of these will remain unchanged when a sound wave travels from the air to water?

- A. amplitude
- B. frequency
- C. speed
- D. wavelength

**Item 16**

A lab group designs an experiment to test which of four identical bottles will produce the sound with the highest pitch when air is blown across the opening at the top. Their initial hypothesis is that the highest pitches are produced when equal amounts of water and air are in the bottle. When blowing air across the tops of the bottles, Bottle 4 produces the sound with the highest pitch.

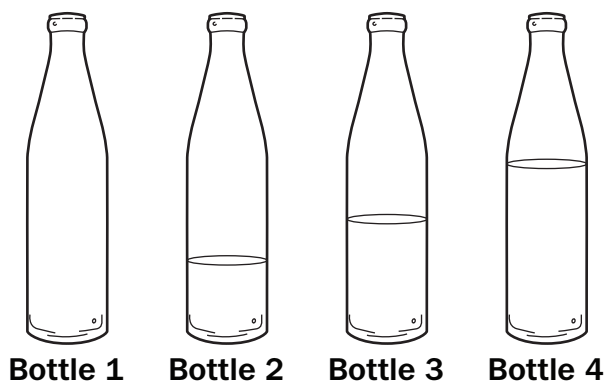

Which would be the **BEST** hypothesis based on their results?

- A. The pitch of the sound produced when air is blown across a bottle does not depend on the contents of the bottle, but only on the size of the bottle.
- B. The highest pitches are produced when the total mass of air in the bottle is greater than the total mass of the water in the bottle.
- C. Sounds with the highest pitch are produced when all air is removed from the bottle.
- D. The pitch of the sound increases as the amount of air in the bottle decreases.

## Unit 5: Science with Toys

In this unit, you will focus on acquiring a conceptual understanding of energy conservation; heat transfer processes; and the relationships between force, mass, and acceleration through the study of familiar toys. You will investigate how simple machines can be combined to build toys that are capable of completing a task with minimal or no human intervention. Throughout this unit, you will be expected to analyze scientific data by collecting, using, interpreting, and comparing experimental results.

### KEY TERMS

**Velocity** is a quantity that measures the rate of an object changing its position. If you take a step forward and then a step back to the original position, the velocity is unchanged because the motion did not result in a change in your position. If you take two steps forward, your position has changed. Your velocity is “two steps forward.” Velocity always describes a distance and a direction. (S8P3a)

**Acceleration** is a quantity that measures the rate at which an object changes its velocity. People often talk about an object decelerating when the object slows down. An object that slows down is actually experiencing a negative acceleration. This means the rate of change is a negative value. An object can have a velocity but not acceleration if it is moving at a constant speed. Let’s say you take a car trip that takes one hour. The velocity of the car is 40 miles east. The average speed of the trip is 40 miles per hour (mph). In the middle of the trip, the car accelerated to 50 mph for 10 minutes and then accelerated to 30 mph for 10 minutes. (S8P3a)

A **force** is a push or pull on an object. Force can be the result of contact, such as when you push a book across your desk. Forces can also result when objects are not in contact with each other. When you use one magnet to push another magnet, there is a force that acts on the magnets although the magnets are not in contact. (S8P3b)

When two or more forces act on an object but the object’s velocity does not change, it is said the object is being acted on by **balanced forces**. A book on your desk that is not moving is said to be **stationary**. The book is said to be at **rest** in relation to the desk. Gravity is acting to pull the book down. The desk pushes up against the book and the book is at rest in relation to the desk. (S8P3b)

An accelerating object is being acted on by **unbalanced forces**. When you push your book across your desk, you are applying force to one side of the book. The force of friction acts on the book in the opposite direction that it is moving, reducing the speed at which the book moves. Because the book still begins to move in the direction you are pushing it, we say that these forces are unbalanced. (S8P3b)

**Friction** is the force that resists motion between two surfaces. When you rub your hands together, friction creates heat. (S8P3b)

**Inertia** is the resistance to any change in the state of motion of any physical object. All matter has inertia until unbalanced forces act on it and cause it to move. (S8P3b)

**Gravity** is the force of attraction that exists between any two or more masses. Gravity can refer to the force that Earth exerts on everything. Because the force of gravity for each object is related to the mass of the object, larger objects, such as Earth, exert a greater gravitational force than objects that have less mass, such as a human. (S8P3b)

**Simple machines** are devices that change the direction or amount of force used to do work. There are six simple machines (lever, inclined plane, pulley, wedge, screw, and wheel and axle). (S8P3c)

The **lever** is a simple machine made up of a straight beam and a fulcrum, a point that the rod pivots on. Levers change the amount of force required to move an object. A seesaw is an example of a lever. (S8P3c)

An **inclined plane** is a simple machine that uses a flat surface to help raise or lower a load. Inclined planes spread the amount of force required to lift a load over a distance. Wheelchair ramps are an example of an inclined plane. (S8P3c)

A **pulley** is a simple machine made up of a wheel around an axle. Pulleys change the direction of a force. Certain pulley combinations can also change the amount of force required to move an object. (S8P3c)

A **wedge** is a simple machine made up of one or two inclined planes. Wedges can change the direction of a force from a straight line to perpendicular to that force. A wedged doorstop is an example of a wedge. The door tries to close. By putting a wedged doorstop between the door and the floor, the force of the door closing is turned 90 degrees and applied to the floor. The floor then resists the door closing. Knives are also an example of a wedge. (S8P3c)

A **screw** is a simple machine that can be thought of as an inclined plane wrapped around an axle. Because of this, the force required to do something is spread out over a longer distance. (S8P3c)

The **wheel and axle** is a simple machine made up of a wheel and an attached axle. The wheel and axle transfers the force from the wheel to the axle. (S8P3c)

### **Important Tip**

✍ Simple machines can be found all around us in our daily lives. Wheelbarrows, bottle openers, and even your elbows are all levers. The inside of a screw-top lid is actually a screw. Doorknobs, wrenches, steering wheels, and even Ferris wheels are all wheel and axles. Pulleys are used in elevator cabling. Wedges can be found in scissors and even zippers! (S8P3c)

**Sample Items 17–20****Item 17**

Identical materials are used to construct the systems shown to lift a large toy block.

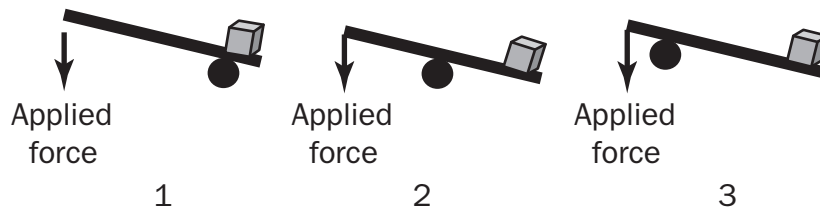

Which statement is **TRUE** about the diagrams shown?

- A. Diagram 1 will give the greatest mechanical advantage because the fulcrum is placed close to the load (toy block).
- B. Diagram 3 will give the greatest mechanical advantage because the fulcrum is placed far from the load (toy block).
- C. Diagram 3 will give the greatest mechanical advantage because the fulcrum is placed closest to the applied force (toy block).
- D. Diagram 2 will give the greatest mechanical advantage because the fulcrum is placed evenly between the load (toy block) and the applied force.

**Item 18**

A student placed a stuffed animal on the dashboard of a car. When the car accelerated quickly, the stuffed animal flew back onto the seat.

Which principle **BEST** describes the motion of the stuffed animal as the car accelerated?

- A. gravity
- B. inertia
- C. momentum
- D. speed

## Item 19

Students are exploring the relationship between velocity and acceleration. This graph shows the acceleration of a remote-controlled toy car.

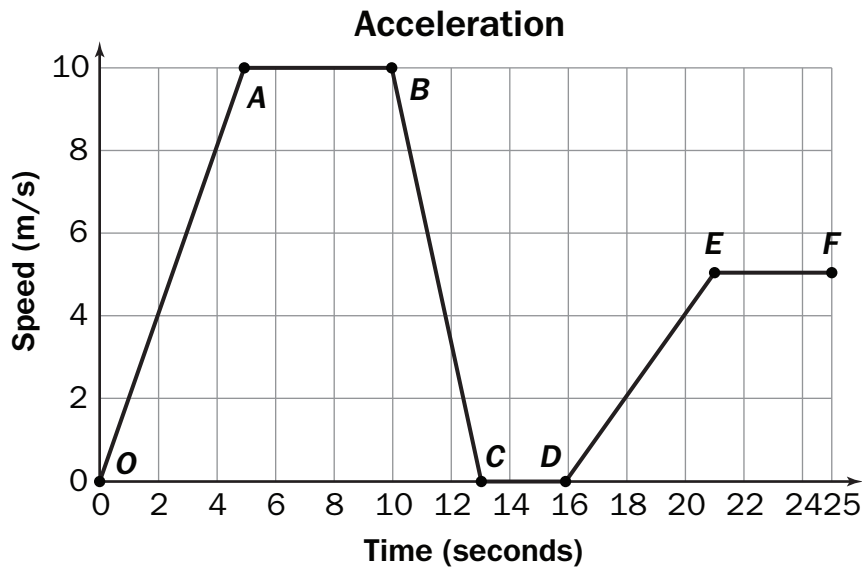

Which statement is TRUE based on the graph?

- A. Segment  $BC$  and Segment  $EF$  show constant speed.
- B. Segment  $OA$  and Segment  $BC$  show constant speed.
- C. Segment  $AB$  and Segment  $CD$  show positive acceleration.
- D. Segment  $OA$  and Segment  $DE$  show positive acceleration.

## Item 20

A skydiver jumps from an airplane. The skydiver experiences the force of gravity,  $F_{\text{grav}}$  and the force of air resistance,  $F_{\text{air}}$ . The diagram shows three different stages in the skydiver's motion.

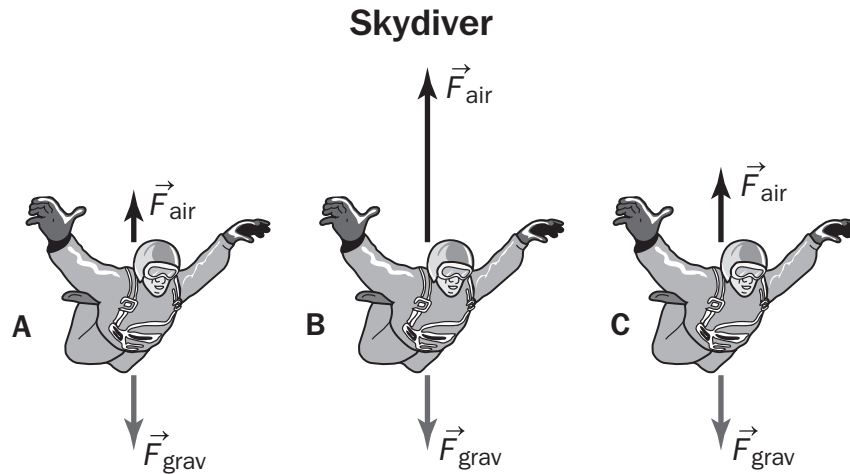

Which statement about the skydiver's motion is TRUE?

- A. The skydiver is not moving at Stage B.
- B. The skydiver is speeding up at Stage B.
- C. The skydiver is slowing down at Stage A.
- D. The skydiver is moving at constant speed at Stage C.

## SCIENCE ADDITIONAL SAMPLE ITEM KEYS

Item	Standard/ Element	Characteristics of Science	DOK Level	Correct Answer	Explanation
1	S8P1b	S8CS9b	2	C	<p>The correct answer is choice (C) Student 1 is correct, while Student 2 is incorrect. Beaker A had a clear liquid, part of which boiled off and part of which formed a solid powder. This indicates it was most likely a mixture, and therefore, the salt water. Beaker B also had a clear liquid, but all of it boiled off so it was most likely the pure water, and therefore, a pure substance. Choice (A) is incorrect because Student 2 incorrectly identifies the identities of the liquids. Choice (B) is incorrect because Student 1 correctly identifies the mixture and the pure substance. Choice (D) is incorrect because Student 1 is correct and Student 2 is incorrect, as previously explained.</p>

Item	Standard/ Element	Characteristics of Science	DOK Level	Correct Answer	Explanation
2	S8P2b	S8CS5a	2	C	<p>The correct answer is choice (C) The ball has maximum potential energy at Point 2 and maximum kinetic energy at Point 4. When the ball reaches maximum height, its gravitational potential energy is greatest. When it is at its lowest point, that gravitational potential energy has been converted into kinetic energy. Therefore, Point 2 will be the point of maximum potential energy and Point 4 represents the point of maximum converted kinetic energy. Choice (A) is incorrect because gravitational potential energy is greatest when the ball is highest, not lowest. Choice (B) is incorrect because although the ball has some amount of gravitational potential energy at Point 1, it is not the maximum. Point 3 is not the maximum kinetic energy; this is at Point 4. Choice (D) is incorrect because potential energy is changing to kinetic energy at Point 3. It is not a maximum for either. At Point 2, the ball is changing direction so its kinetic energy is not at a maximum.</p>



Item	Standard/ Element	Characteristics of Science	DOK Level	Correct Answer	Explanation
3	S8P2a	S8CS1b	3	C	The correct answer is choice (C) The pendulum stopped due to friction, and according to the Law of Conservation of Energy, no energy is lost, just changed from potential energy to thermal energy. According to the Law of Conservation of Energy, energy cannot be created or destroyed. The total amount of energy is the same before or after any practice. In this case, the pendulum encountered friction and the mechanical energy was converted to thermal energy. No energy was lost in the experiment; it was transformed. Choices (A) and (B) are incorrect because they use an incorrect definition of the Law of Conservation of Energy. This law states that energy cannot be lost. Choice (D) is incorrect because it incorrectly attributes a loss of energy to gravity. No energy is lost according to the Law of Conservation of Energy.
4	S8P3b	S8CS5a	2	C	The correct answer is choice (C) The object will remain stationary. The forces are balanced in opposite directions and would cancel each other out; therefore, no motion would occur. Choice (B) is incorrect because since no motion is occurring, a direction change would not occur. Choices (A) and (D) are incorrect because the forces are balanced, so no motion would occur.

Item	Standard/ Element	Characteristics of Science	DOK Level	Correct Answer	Explanation
5	S8P1c	S8CS5a	1	A	The correct answer is choice (A) The particles are moving quickly and are far apart. A gas is composed of particles that are moving quickly and spread out. Gases will expand to take the shape of a container because gases will spread out across any volume in a consistent manner so all the atoms are spaced equally. Choice (B) is incorrect because it is the definition of a solid. Choice (C) is incorrect because it is the definition of a liquid. Choice (D) is incorrect because gas particles are not packed tightly together.
6	S8P1e	S8CS9b	2	A	The correct answer is choice (A) 2, 3, 6 because these three processes result in a chemical change. Choice (B) is incorrect because processes 1 and 4 are examples of physical changes. Choice (C) is incorrect because all processes are examples of physical processes. Choice (D) is incorrect because process 5 is an example of a physical process.
7	S8P1g	S8CS9b	2	D	The correct answer is choice (D) Law of Conservation of Matter. According to the Law of Conservation of Matter, during any physical or chemical change, the total mass of the products remains equal to the total mass of the reactants. Choices (A), (B), and (C) are incorrect because they either identify other scientific laws or ideas that are not scientific laws.

Item	Standard/ Element	Characteristics of Science	DOK Level	Correct Answer	Explanation
8	S8P2d	S8CS7c	2	C	<p>The correct answer is choice (C) This shows how convection currents move as the water warms and cools, causing it to rise or sink. The blue ice water is denser and it sinks. It is then heated by the hot plate, which causes its density to decrease. As a result, the blue water rises. The warm red water stays near the top of the aquarium. Near the surface and near the cup of ice, it cools. This causes its density to increase, so it sinks. It is then heated and a circular convection current is formed. The temperature of the water continuously changes as it is heated and cooled. Choice (A) is incorrect because the dye only makes it easier to trace the movement of the water. It does not affect the speed or direction of motion. Choice (D) is incorrect because heat is transferred from warmer matter to cooler matter, so it would be transferred from the warm red water to the ice cubes in the cup or the cool water coming out of the cup. Choice (B) is incorrect because the heating does not occur through radiation and the cold water will rise upon heating, not sink.</p>

Item	Standard/ Element	Characteristics of Science	DOK Level	Correct Answer	Explanation
9	S8P2c	S8CS5a	2	C	The correct answer is choice (C) electricity to motion. The fan receives electrical energy and converts this to motion energy to move the spinning blades. Choice (A) is incorrect because sound energy is not being converted into motion. Choice (B) is incorrect because heat is lost from the system, not used by the system. Choice (D) is incorrect because a fan is an example of electricity being converted into motion energy. This is presented in reverse.
10	S8P5b	S8CS5b	2	C	The correct answer is choice (C) It will stop working. This is a series circuit, and in a series circuit, if one of the bulbs stops working, all the bulbs stop working. Choices (A) and (D) are incorrect for a series circuit. If it were a parallel circuit, Bulb A would not go out but would stay lit and might get brighter depending on the type of bulb, but it is a series circuit, not a parallel circuit. Choice (B) is incorrect; the bulb would stop working, not just get dimmer, since the circuit is a series circuit.
11	S8P5c	S8CS5a	2	B	The correct answer is choice (B) run electricity through the wire. The needle of a compass is diverted when it is brought near a current-carrying wire. Choice (A) is incorrect because the motion of a wire does not create a magnetic force. Choice (C) is incorrect because bending a wire does not create a force on a magnet. Choice (D) is incorrect because bringing a compass closer to a magnet might cause the needle to move, but moving it closer to a wire will not.

Item	Standard/ Element	Characteristics of Science	DOK Level	Correct Answer	Explanation
12	S8P2b	S8CS5a	2	C	The correct answer is choice (C) Kinetic energy changes to potential energy as the bob moves from Position D to Position E. Kinetic energy, which is the energy of motion, is greatest at the bottom of the swing where height is lowest. As the bob moves to Position E, it gets slower and higher, so its potential energy increases. Choice (A) is incorrect because in Position A, the bob is not yet released, so it has no motion and its height is greatest. Thus all of its energy is potential energy. Choice (B) is incorrect because in Position C, the bob is moving at the greatest speed and is in the lowest position. Its gravitational potential energy is at its lowest in the pendulum motion at this point. Choice (D) is incorrect because potential energy changes to kinetic wherever the bob is moving downward and getting faster. This occurs from Position A to Position C.
13	S8P4a	S8CS9b	2	D	The correct answer is choice (D) The frequency decreases and the amplitude decreases. The sound getting quieter is an effect of the decrease in amplitude. A lowering in pitch is a decrease in the frequency. Choices (A), (B), and (C) are incorrect because they do not correctly explain how the wave changes.

Item	Standard/ Element	Characteristics of Science	DOK Level	Correct Answer	Explanation
14	S8P4b	S8CS7a	2	A	The correct answer is choice (A) The chemical absorbs the light from the visible spectrum except for red that is reflected to the eye. The surface of the cloth absorbs all the colored light rays, except for those corresponding to red, and reflects this color to the human eye. Choice (B) is incorrect because all the colors of the visible spectrum EXCEPT for red are absorbed. Choice (C) is incorrect because light is reflected, not refracted. Choice (D) is incorrect because the chemical does not produce light, but light is reflected.
15	S8P4d	S8CS5a	2	B	The correct answer is choice (B) frequency. Frequency relies only on the source making the sound wave and is not affected by the medium. Choices (A), (C), and (D) are incorrect because the medium affects all these properties of the sound wave.
16	S8P4e	S8CS5a	2	D	The correct answer is choice (D) The pitch of the sound increases as the amount of air in the bottle decreases. Choice (A) is incorrect because the experiment showed that changing the contents of the bottle did change the pitch of the sound produced. Choice (B) is incorrect because Bottle 4 has more water than air. The mass of the water is greater than the mass of air. Choice (C) is incorrect because none of the bottles in the experiment were filled completely with water and no air. The students could not form this hypothesis based on their observations.

Item	Standard/ Element	Characteristics of Science	DOK Level	Correct Answer	Explanation
17	S8P3c	S8CS5a	2	A	The correct answer is choice (A) Diagram 1 will give the greatest mechanical advantage because the fulcrum is placed close to the load (toy block). The fulcrum is placed close to the load, and this will allow movement of the load with a small applied force. Choice (B) is incorrect because the fulcrum is close to the area of the applied force. This will require much more force and therefore reduce the mechanical advantage. Choice (C) is incorrect because this will require more force. Choice (D) is incorrect because the fulcrum is halfway between the force and the load, so there is no mechanical advantage.
18	S8P3b	S8CS5a	2	B	The correct answer is choice (B) inertia. The definition of inertia is an object's tendency to resist a change in motion. The stuffed animal was at rest and resisted the change in forward motion. Choice (A) is incorrect because, although gravity is present in this situation, it is not causing the stuffed animal to appear to move backward. Choice (C) is incorrect because momentum is mass in motion and is defined as the mass times the velocity. Choice (D) is incorrect because speed would be the distance an object traveled divided by the time.

Item	Standard/ Element	Characteristics of Science	DOK Level	Correct Answer	Explanation
19	S8P3a	S8CS6c	2	D	<p>The correct answer is choice (D) Segment <i>OA</i> and Segment <i>DE</i> show positive acceleration. Both show positive acceleration because as the time increases, so does the speed as shown by the upward-sloping line. Choice (A) is incorrect because Segment <i>BC</i> shows negative acceleration and Segment <i>EF</i> shows constant speed. Choice (B) is incorrect because Segment <i>OA</i> shows positive acceleration and Segment <i>BC</i> shows negative acceleration, not constant speed. Choice (C) is incorrect because Segment <i>AB</i> shows constant speed as shown by the straight line. Segment <i>CD</i> shows no speed because the segment is plotted at 0.</p>
20	S8P3b	S8CS5a	2	D	<p>The correct answer is choice (D) The skydiver is moving at constant speed at Stage C. The forces of gravity and air resistance are balanced at Stage C, so the skydiver continues to fall, but the speed does not change. Choice (A) is incorrect because the downward force of gravity is less than the upward force of air resistance, so the skydiver is slowing down. Choice (B) is incorrect because the force of air resistance is greater than the force of gravity, so the skydiver is slowing down. Choice (C) is incorrect because the downward force of gravity is greater than the upward force of air resistance, so the skydiver is speeding up.</p>



## ACTIVITY

The following activity develops skills in Unit 2: Food and Cooking (Structure of Matter).

**Standards:** S8P1e, S8P1g

Before beginning, gather the following materials:

- 3 plastic cups
- electronic balance or digital scale
- effervescent tablets (such as those used for indigestion)
- water
- iodine (can be found in the first-aid section of many stores)
- stirrers (such as spoons or straws)
- cornstarch

You can try two experiments to demonstrate the Law of Conservation of Mass.

### Experiment 1

**Step 1:** Measure the mass of the empty cup. Then place a small amount of water (about  $\frac{1}{2}$  cup) and a teaspoonful of cornstarch into the cup and mix.

**Step 2:** Measure the mass of the cup, water, and cornstarch and record the measurements in your science journal.

**Step 3:** Zero the balance with the second empty cup. This will allow you to get the mass of the iodine by itself in Step 4.

**Step 4:** Add 5 drops of iodine to a second cup and record the mass. Add the mass of the water-cornstarch mixture and the mass of the iodine together.

**Step 5:** Add the iodine to the cornstarch mixture and stir. Record results.

**Step 6:** Evidence in Step 5 indicates a chemical change has taken place. Measure the mass of the new mixture and record the measurements in your science journal. Compare the mass of the mixtures before and after they were combined.

### Questions:

- *Did the mass change before and after the reaction?*
- *How do you know that a chemical reaction took place? Cite evidence from the experiment to support your answer.*
- *How can you explain the results in terms of the Law of Conservation of Mass?*

### Experiment 2

**Step 1:** Zero the balance with the empty beaker or cup. This will allow you to get the mass of the reactants by themselves in Step 2.

**Step 2:** Place a small amount of water (about half the total volume) into the cup.

**Step 3:** Put the effervescent tablet on the balance beside the cup, but do not put it in the water yet. Record the total starting mass in your science journal.

**Step 4:** Leave the cup on the balance and drop the tablet into the cup of water. Record your observations.

**Step 5:** Evidence in Step 4 indicates a chemical change has taken place. After the reaction has finished, measure the mass of the new mixture and record the measurement in your science journal.

### Questions:

- *Did the mass change before and after the reaction?*
- *How do you know that a chemical reaction took place? Cite evidence from the experiment to support your answer.*
- *Does this experiment agree with the Law of Conservation of Mass? How can you explain the results in terms of the Law of Conservation of Mass?*

## ACTIVITY

The following activity develops skills in Unit 5: Science with Toys.

**Standards:** S8P3a, S8P3b, S8P5a

Gather the following materials:

- 3 marbles of different weights/mass
- inclined plane/track for rolling marbles
- books for changing height of track
- empty carton or box
- ruler

### Experiment 1

**Step 1:** Using books and the track, set up a track so marbles will roll easily. The track does not have to be very high.

**Step 2:** Place the carton in front of the track so when the marble leaves the end of the track, it will hit the carton. Using the smallest marble, start it at the top of the track and release it. (See Diagram 1)

**Diagram 1**

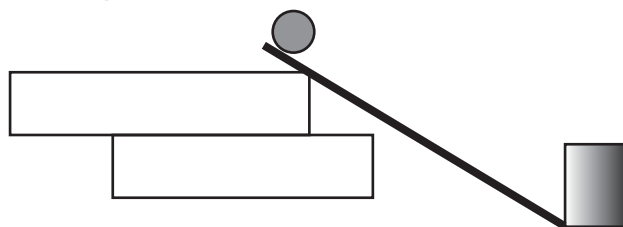

**Step 3:** Measure how far from the track the marble pushed the carton in centimeters and record the measurement in your science journal.

**Step 4:** Repeat this two (2) more times and average all three (3) distances together. Record this result in your science journal.

**Step 5:** Using the next-largest marble, repeat Steps 2–4 by releasing the marble three (3) times down the track and recording the distance the carton was moved each time. Average all times.

**Step 6:** Repeat the process again with the largest marble. Record distances in your science journal and average all three (3) distances together.

### Questions:

- Which marble had the most potential energy? How do you know that?
- What statement can you make about the relationship of mass and potential energy?

### **Experiment 2**

- Step 1:** Add books to the track from Experiment 1 so that it is twice as high as it was in Experiment 1.
- Step 2:** Place the carton in front of the track so when the marble leaves the end of the track, it will hit the carton. Release the smallest marble from the top of the track.
- Step 3:** Measure how far from the track the marble pushed the carton in centimeters and record the distance in your science journal.
- Step 4:** Repeat this two (2) more times and average all three (3) distances together. Record your observations in your science journal.
- Step 5:** Using the next-largest marble, repeat Steps 2–4.
- Step 6:** Repeat the process again with the largest marble.

### **Questions:**

- *Compare the average distance the smallest marble pushed the carton in Experiment 1 and Experiment 2. In which experiment did the carton go the farthest?*
- *What statement can you make about the relationship of height and potential energy?*
- *Where did the marble have the greatest potential energy?*
- *Where did the marble have the greatest kinetic energy?*

---

## SOCIAL STUDIES

### DESCRIPTION OF TEST FORMAT AND ORGANIZATION

The Grade 8 Social Studies EOG assessment has a total of 75 selected-response (multiple-choice) items.

The test will be given in two sections.

- You may have up to 70 minutes per section to complete Sections 1 and 2.
- You will have about 90 to 140 minutes for the complete Social Studies EOG assessment.

### CONTENT

The Grade 8 Social Studies EOG assessment will measure the Grade 8 Social Studies standards that are described at [www.georgiastandards.org](http://www.georgiastandards.org).

The content of the assessment covers standards that are reported under these domains:

- History
- Geography
- Government and Civics
- Economics

### ITEM TYPES

The Social Studies portion of the Grade 8 EOG assessment consists of selected-response (multiple-choice) items only.

## **SOCIAL STUDIES DEPTH OF KNOWLEDGE EXAMPLE ITEMS**

Example items that represent applicable DOK levels of the Social Studies assessment are provided on the following pages. The items and explanations of what is expected of you to answer them will help you prepare for the test.

**All example and sample items contained in this guide are the property of the Georgia Department of Education.**

### **Example Item 1**

**DOK Level 1:** This is a DOK level 1 item because it asks students to recall a fact.

**Social Studies Grade 8 Content Domain:** History

**Standard:** SS8H2. The student will analyze the colonial period of Georgia's history.

a. Explain the importance of James Oglethorpe, the Charter of 1732, and reasons for settlement (charity, economics, and defense), Tomochichi, Mary Musgrove, and the city of Savannah.

**Who was the founder of the colony of Georgia?**

- A. Tomochichi
- B. Elijah Clark
- C. Mary Musgrove
- D. James Oglethorpe

**Correct Answer:** D

**Explanation of Correct Answer:** The correct answer is choice (D) James Oglethorpe. Choice (A) is incorrect because although Tomochichi helped early settlers, he was not Georgia's founder. Choice (B) Elijah Clarke is incorrect because he was an important figure during the American Revolution, not the founder of Georgia. Choice (C) is incorrect because Mary Musgrove interpreted for the founder of Georgia but was not its founder.

## Example Item 2

**DOK Level 2:** This is a DOK level 2 item because it involves reasoning and comparing.

**Social Studies Grade 8 Content Domain:** Geography

**Standard:** SS8G1. The student will describe Georgia with regard to physical features and location. b. Describe the five geographic regions of Georgia; include the Blue Ridge Mountains, Valley and Ridge, Appalachian Plateau, Piedmont, and Coastal Plain.

**Read the information in the box.**

This region of Georgia contains the highest elevation in the state. This area also receives the most rainfall of any of the regions.

**Which geographic region is described in the box?**

- A. Coastal Plain
- B. Valley and Ridge
- C. Appalachian Plateau
- D. Blue Ridge Mountains

**Correct Answer:** D

**Explanation of Correct Answer:** The correct answer is choice (D) Blue Ridge Mountains. This region contains the highest mountain range and receives the most rain of all the regions in the state of Georgia. Choices (A), (B), and (C) are all incorrect because they are regions in the state that do not match the description in the box. They receive less rain and are at lower elevations than the Blue Ridge Mountains.

### Example Item 3

**DOK Level 3:** This is a DOK level 3 item because students must analyze the information in the chart in order to draw a conclusion about the forms of city government listed and compare the options.

**Social Studies Grade 8 Content Domain:** Government and Civics

**Standard:** SS8CG5. The student will analyze the role of local governments in the state of Georgia. b. Compare and contrast the weak mayor-council, the strong mayor-council, and the council-manager forms of city government.

Read the information in the chart.

	Forms of City Government		
	Strong Mayor-Council	Weak Mayor-Council	Council-Manager
Executive Role and Responsibility	Most power rests with the mayor	Most power rests with the council	City Manager
Policymaking Responsibility	Power rests with the council, but the mayor may have the ability to veto	Power rests with the council	Council
Who Has the Most Power	Mayor	Council	Council

Based on the information in the chart, which of these describes an advantage of a weak mayor-council form of government?

- A. Executive duties are subjected to a system of checks and balances.
- B. Executive power is shared among others rather than reserved for one person.
- C. Executive functions are centralized so that they can be handled by only one person.
- D. Executive responsibility and policymaking are split between two branches of government.

**Correct Answer:** B

**Explanation of Correct Answer:** The correct answer is choice (B) Executive power is shared among others rather than reserved for one person. The weak mayor-council disperses the power among the members of the city council, with some power for the mayor. Choice (A) is incorrect because most of the power resides with the council and the mayor does not balance this power. Choice (C) is incorrect because most executive power rests with the council, which is made up of many people. Choice (D) is incorrect because both the council and the mayor exercise executive responsibilities.



## SOCIAL STUDIES CONTENT DESCRIPTION AND ADDITIONAL SAMPLE ITEMS

In this section, you will find information about what to study in order to prepare for the Grade 8 Social Studies EOG assessment. This includes key terms and important vocabulary words. This section also contains practice questions, with an explanation of the correct answers, and activities that you can do with your classmates or family to prepare for the assessment.

The organization of Social Studies units in this guide is based on Frameworks developed by the Curriculum and Instruction Division of the Georgia Department of Education. The Social Studies section begins with Unit 2. Unit 1 focuses on overarching themes and concepts, rather than on specific standards. Unit 1 will, therefore, not be a part of the End-of-Grade assessment. These Frameworks can be accessed at <https://www.georgiastandards.org/Frameworks/Pages/BrowseFrameworks/socialstudies6-8.aspx>.

**All example and sample items contained in this guide are the property of the Georgia Department of Education.**

### CONTENT DESCRIPTION

The four domains (History, Geography, Government/Civics, and Economics) are fully integrated.

**Some of the topics you will study in this guide are the following:**

- Georgia history, geography, government, and economics
- Georgia's role in the history of the United States and the impact of historical events on the state with a primary focus on the period from the Civil War to the present
- Georgia's role in and contributions to American history
- The impact of historical figures and events and how they shape and define contemporary economic, political, and social conditions in Georgia
- The influence of location and physical features on economic growth and development in the state of Georgia
- Georgia's location relative to the nation, continent, and Western Hemisphere
- The process of government in the state of Georgia and the political role of citizens under its constitution
- The political and legal structures and institutions that govern Georgia
- The factors that have influenced and shaped Georgia's economic growth and development
- The importance of both domestic and international trade, the role of the entrepreneur in generating economic growth and productivity, and government revenue sources

## Unit 2: Georgia Geography and the Prehistoric Period

In this unit, you will study the geography of Georgia. You will learn about the rivers, mountains, plains, and plateaus. You will locate specific places, such as the Barrier Islands and Okefenokee Swamp. You will learn about the climate in the state. You will also learn about the development that occurred among prehistoric cultures.

### KEY TERMS

**Appalachian Mountains:** A large mountain chain in eastern North America extending from Canada into Alabama. (G1c)

**Appalachian Plateau:** A region in northwest Georgia known for its mountains. It is part of the larger Appalachian mountain range. (G1b)

**Barrier Islands:** A group of mostly undeveloped islands along Georgia's coast. (G1c)

**Blue Ridge Mountains:** A mountainous region in northern Georgia that is a branch of the Appalachian mountain chain. (G1b)

**Chattahoochee River:** A long river that flows from northern Georgia along the Georgia/Alabama border and into the Apalachicola River. The river is used for rafting and fishing and is a national recreation area. (G1c)

**Coastal Plain:** A low-lying and mostly flat region of Georgia that covers most of the state's southern half. It has sandy beaches, flatlands, and gently rolling hills. (G1b)

**Fall Line:** A geological boundary that divides the rocks of the upper Coastal Plain from those of the Piedmont. Because the line is marked by rivers, it has been a center for commerce and trade throughout Georgia's history. (G1c)

**Georgia:** A state in the southern United States and the last of the thirteen original colonies. It is the largest state east of the Mississippi River. Parts of Georgia have a subtropical climate, but the areas northwest of the Chattahoochee River are cooler. The state is the largest producer of peanuts in the United States. (G1a)

**Mississippian culture:** An early native culture, which settled the midwestern and southeastern parts of what is today the United States. The Mississippian people cultivated the land, gathered nuts and berries, and hunted. They existed as a group from about CE 800\* to 1600 and then split into a number of Native American groups. (H1a)

**Native Americans:** Many groups of Native Americans once made what is now Georgia their home, including the Apalachicola, Cherokee, Muscogee, and Yamacraw tribes. (H1a)

**Okefenokee Swamp:** A large but shallow wetland in southeast Georgia and northeast Florida. Much of the area is today protected as part of a national refuge. (G1c)

**Paleo culture:** An early native culture which lived in the Southeast during the Ice Age, from approximately 10,000 to 8000 BCE\*\*. The Paleo people were nomadic and depended mainly on animals for food. (H1a)

**Piedmont:** A region of Georgia located between the Coastal Plain in the south and mountains in the north. It is hilly, the second-largest region of the state, and the most populated. (G1b)

\*CE: Common Era, previously known as AD

\*\*BCE: Before common era, previously known as BC

**Savannah River:** A river that begins in South Carolina, flows along the South Carolina and Georgia border, and empties into the Atlantic Ocean. It is about 300 miles long. (G1c)

**Valley and Ridge:** A region located in northwest Georgia, marked by high ridges that overlook deep, wide valleys. (G1b)

## KEY IDEAS

### Georgia's Climate

Georgia has a climate as diverse as its topography.

Summers are hot and winters mild, thanks to Georgia's subtropical location in the Northern Hemisphere. The northern part of the state, which is more mountainous, tends to be colder and snowier. The line of division between these two climate regions is the Chattahoochee River.

With the Atlantic Ocean bordering the state on the east and a coastal plain to the south, Georgia does not lack precipitation. Tornadoes occur, usually carried by storms from the west. Hurricanes are less common but occasionally move inland from the ocean. (G1d)

### Native American Cultures

Time Period	Native Americans	Historical Significance
12,000 BCE–8,000 BCE	Paleo Indians	The first humans in Georgia; they were nomadic hunters and gatherers who hunted large game such as mastodons and giant bison.
8,000 BCE–1,000 BCE	Archaic Indians	The second oldest Native American culture in Georgia; they are nomadic hunters who hunted smaller game and are credited with developing grooved axes, the atlatl, fish hooks, and pottery.
1,000 BCE–700 CE	Woodland Indians	The third prehistoric Native American culture in Georgia; they were credited for the development of the bow and arrow, pottery for storage, and intensification of horticulture, as well as building small mounds.
800 CE–1,600 CE	Mississippian Indians	The last major prehistoric Native American culture in Georgia; they are known for being large-scale farmers and mound builders who traded throughout North America. This group was the first to meet Europeans.

## Sample Items 1–2

### Item 1

**In which Native American culture was the shift made from hunting and gathering to farming?**

- A. Paleo
- B. Archaic
- C. Woodland
- D. Mississippian

### Item 2

**Which statement describes a difference between the Woodland culture and the Mississippian culture?**

- A. Mississippian society was organized into chiefdoms.
- B. Trading with other groups was part of the Woodland culture.
- C. Farming was an important activity for the Woodland Indians.
- D. The people of Mississippian culture constructed mounds.

## Unit 3: Exploration and Colonization

In this unit, you will learn about Georgia's past. You will study the explorers who came here and set up colonies. You will learn about the Native Americans who lived in Georgia. You will read about the royal governors who ruled the state at one time.

### KEY TERMS

**Charter of 1732:** Signed by King George II, it established the royal colony of Georgia and appointed a Board of Trustees to govern it. (H2a)

**Hernando de Soto:** A Spanish explorer and *conquistador* who landed in what came to be known as Florida in 1539. He explored the Southeast, including Georgia, from 1539 to 1542. He and his 600 men searched for wealth, sparking conflict with the Native American groups whom they exploited and enslaved. (H1b)

**European Exploration:** The French, Spanish, and British all sent explorers to the southeastern part of North America. The Spanish, believing the area to be rich in gold, searched for wealth. They also believed it was their mission to convert the natives to Christianity. The French sought to found an empire based on trade in furs, fish, and sugar. The British wanted to colonize the area for a number of reasons. Some sought the riches offered by the area's abundance of resources. Others hoped to escape religious persecution in Europe. (H1c)

**Highland Scots:** A group of Scottish people from the area of Inverness who came to Georgia in the 1730s. They founded the city of Darien along the colony's southern border. (H2b)

**Land Ownership:** Under the royal charter signed by King George II, colonists were not permitted to own land. This caused discontent, due to their hard work in developing and cultivating the region. (H2c)

**Malcontents:** A group of mostly Scottish colonists who loudly opposed the policies of James Oglethorpe and Georgia's Board of Trustees. (H2b)

**Mary Musgrove:** A Native American woman who was James Oglethorpe's Creek interpreter and emissary during Georgia's earliest years. (H2a)

**Native Americans:** Many groups of Native Americans made what is now Georgia their home, including the Apalachicola, Cherokee, Muscogee, and Yamacraw tribes. (H1b)

**James Oglethorpe:** The British general and philanthropist who founded the colony of Georgia. Oglethorpe was one of the original trustees and the only trustee to come to Georgia. (H2a)

**Royal Governors:** After the Trustees refused to continue overseeing Georgia's daily operations, the king appointed a series of governors to lead the colony. The first royal governor introduced the self-government to colonists, but later took it away. The second governor reintroduced self-government. The third became popular because of his successful economic policies. (H2c)

**Salzburgers:** A group of German-speaking Protestant refugees who helped settle the colony of Georgia in the 1730s. (H2b)

**Savannah:** A Georgia city near the mouth of the Savannah River, founded in 1733 by James Oglethorpe. (H2a)

**Slavery:** Oglethorpe banned slavery in the colony of Georgia. This led to conflicts with colonists who believed that slaves were needed to work the land. (H2c)

**Spanish Missions:** Places of worship set up by Spanish Catholic missionaries to convert native peoples to Christianity. In Georgia, many such places were established along the Barrier Islands. (H1b)

**Tomochichi:** A Creek leader who acted as a mediator between British settlers in Georgia and the native population of the region. (H2a)

**Trustee Period:** From 1732 to 1752, a Board of Trustees governed the colony of Georgia. (H2b)

**War of Jenkins' Ear:** During the 1730s and 1740s, Great Britain and Spain engaged in a number of military conflicts, some of which took place in Georgia and Florida. As a result, Georgian colonists feared violent attacks by the Spaniards who held Florida. (H2b)

## Sample Items 3–4

### Item 3

Read the information in the chart.

	Dates of Exploration/ Colonization of the Southeast	Motives for Exploration and Colonization	Key Details
Spanish	1500s–1600s	Conversion of Native Americans to Catholicism, adaptation of Native Americans to Spanish social and economic colonial system, and the search for silver and gold	The Spanish established missions which eventually collapsed due to Native American deaths by disease and slave raids by English traders.
French	1500s	To claim land in the Southeast, and find resources to trade	Although the French managed to establish colonies north and south of Georgia in South Carolina and Florida, both colonies were short-lived.
British	1600s	To find deerskins and other items to trade, claim land in the Southeast, and limit Spanish influence in Florida	The British trade led to the disruption of Native American societies in the Southeast.

Which conclusion can **BEST** be drawn from this chart?

- A. The Spanish supported French land claims in the Southeast.
- B. The Spanish had the least impact on the Native Americans in the Southeast.
- C. The Spanish, French, and British all had economic interests in the Southeast.
- D. The Spanish, French, and British all wanted to bring their religion to the Southeast.

### Item 4

**Read the information in the box.**

- Many Native Americans converted to a new religion.
- Native Americans allied themselves with various European groups.
- Many Native Americans became ill from newly introduced diseases.
- Native American economies responded to European demand for goods.

**Which of these was the MAIN cause of the conditions listed in the box?**

- A. the American Revolution
- B. the Spanish search for gold
- C. European exploration and colonization
- D. European involvement in the slave trade



## Unit 4: Statehood

In this unit, you will study Georgia's history and how Georgia became a state. You will learn about important events in Georgia's past, such as the Battle of Kettle Creek, the invention of the cotton gin, the Dahlonega Gold Rush, the Trail of Tears, and the building of railroads. You will study famous battles of the American Revolution and learn more about key historical figures such as Andrew Jackson and John Marshall.

### KEY TERMS

**Articles of Confederation:** The first constitution of the United States of America. Because it allowed for only a weak central government, it was later replaced with the U.S. Constitution, which established a federal government with a president, a judicial system, and the authority to tax. (H4a)

**Abraham Baldwin:** A delegate from Georgia to the Continental Congress in 1785 and 1787–88. He later served as a representative and senator of the state. (H4b)

**Battle of Kettle Creek:** A battle of the American Revolution, fought in Georgia on February 14, 1779. (H3b)

**Cherokee:** A group of Native Americans who lived in the southeastern United States, including Georgia, before being moved to reservations in Oklahoma and North Carolina. (H5d)

**Elijah Clarke:** An officer in the Georgia Militia who fought in the Battle of Kettle Creek and was a hero of the American Revolution. He later became a legislator in Georgia. (H3b)

**Constitutional Convention of 1787:** A convention to address the problems of federal government, which were weak under the Articles of Confederation. Also known as the Philadelphia Convention. (H4b)

**Cotton Gin:** A machine that separates small particles, such as seeds, from cotton fibers. Its invention in the 1790s made cotton easier to process and cheaper to produce. It had a profound impact on Georgia, where cotton became a large and profitable industry, and it enabled the state to trade with not only other states but also other nations. (H5c)

**Creeks:** A group of Native Americans who lived in the southeastern United States, including Georgia, before being moved to reservations in Oklahoma and Alabama. (H5d)

**Austin Dabney:** A slave who became the only African American man known to have fought in the Battle of Kettle Creek. As a reward for his services, he was given land and a military pension by the state of Georgia. (H3b)

**Dahlonega Gold Rush:** A rush on Georgia sparked by the discovery of gold near the town of Dahlonega. It spread throughout the state and onto land given to Native American groups as part of a treaty. (H5d)

**William Few:** One of Georgia's four representatives to the Constitutional Convention. In addition to signing the U.S. Constitution, he became a senator from Georgia and a strong supporter of public education. (H4b)

**Georgia Constitution of 1777:** The state's first constitution, in effect for twelve years and never ratified by voters. It protected the right to trial by jury, freedom of religion, and freedom of the press, but it also invested most of the state's power in the legislature. (H4a)

**Georgia's State Constitution:** Divides government into three branches: the legislature, which is bicameral; the judiciary, which is headed by the state supreme court; and the executive, which is presided over by the governor. Checks and balances among the branches prevent any one branch from becoming too powerful. (CG1a, b)

**Button Gwinnett:** One of three signers of the Declaration of Independence to come from Georgia. A British-born colonist, he also served in the colonial legislature and the Second Continental Congress. (H3b)

**Lyman Hall:** One of three signers of the Declaration of Independence to come from Georgia. He also served in the Second Continental Congress and as governor of the state of Georgia. (H3b)

**Nancy Hart:** A Patriot from Georgia who sought to remove as many Loyalists and British sympathizers from the colony as possible. (H3b)

**Headright System:** A system in which land was granted to people willing to voyage from Great Britain to settle in the colonies. Georgia employed the system in an effort to grow its population. (H5b)

**Andrew Jackson:** President of the United States during the Georgia gold rush. He ordered the Cherokee and Creek off Georgian land granted to them by a treaty with the U.S. government. (H5d)

**Land Lotteries:** A system employed by the state of Georgia in the early 1800s in which some citizens could register to win land previously held by the Cherokee and the Creek. (H5b)

**Loyalist:** A colonist who remained loyal to the British government during the American Revolution. (H3b)

**John Marshall:** The chief justice of the U.S. Supreme Court at the time of *Worcester v. Georgia*. (H5d)

**Alexander McGillivray:** A controversial Creek leader who was born to a European father and Native American mother. He used his connections with European powers to help benefit his people. (H5d)

**William McIntosh:** A controversial Creek chief who supported the United States in its efforts to take Creek land. (H5d)

**Patriot:** A person who supported breaking from the British government and forming a new government ruled by colonists. (H3b)

**Railroad:** A means of transporting people and goods that made interstate commerce easier and more profitable beginning in the mid-to-late 1800s. (H5b, E2)

**John Ross:** A chief who presided over the Cherokee during their migration from Georgia to Oklahoma, commonly known as the Trail of Tears. (H5d)

**Sequoyah:** A Cherokee scholar who invented a written system to transcribe the spoken Cherokee language. (H5d)

**Siege of Savannah:** A battle of the Revolutionary War that took place in 1779; it was the second-deadliest clash of the war. The British maintained control of Savannah at the end of the siege. (H3b)

**Trail of Tears:** The route along which various Native American groups were forced to walk from the Southeast to reservations west of the Mississippi. (H5d)

**George Walton:** One of three signers of the Declaration of Independence to come from Georgia; he later served as governor of the state. (H3b)

**Worcester v. Georgia:** The case in which the U.S. Supreme Court ruled that states could not make or enforce laws dealing with Native American groups, reserving such authority to the federal government. (H5d)

**Yazoo Land Fraud:** The controversial sale of land by the governor of Georgia and the state's legislature during the mid-1790s. Tracts of land in what would become Mississippi and Alabama were sold cheaply to political supporters. Though reformers later passed a law nullifying the sales, the U.S. Supreme Court overruled the law. (H5b)

## KEY IDEA

### The American Revolution

In the 1750s, conflict between the British and the French over control of North America escalated. The result was a war, known as both the French and Indian War and the Seven Years' War, that lasted from 1754 to 1763. Ultimately, British victories forced the French to sign over much of their territory.

Following the war, King George III signed the Proclamation of 1763, which forbade British colonists from settling west of the Appalachian Mountains. The settlers were unhappy with this, and their discontent grew when the king passed various acts to recoup the costs Britain had incurred during the war. These included the Stamp Act of 1765, which was the first British tax levied directly on American colonists. Every newspaper, pamphlet, and legal document had to include a British seal that was taxed. The Intolerable Acts were passed by Parliament to punish the colonies after the Boston Tea Party. These laws forced American colonists to quarter, or house, British soldiers in their homes and allowed royal officials accused of crimes to be tried in Britain rather than America.

In response, a group of leaders in the colonies formed the Continental Congress. They formally declared their independence from Britain in 1776 in a document known as the Declaration of Independence. They sent the document to King George III, who rejected it. War broke out, the colonists won, and the United States of America became an independent nation. (H3a)

## Sample Items 5–6

### Item 5

**What was one reason for the siege of Savannah during the American Revolution?**

- A. to end the colonial blockade of British ships
- B. to end the British military occupation of the city
- C. to force Savannah Loyalists to support the independence movement
- D. to force Savannah businesses to provide military support to the Patriots

### Item 6

**How did the development of the cotton gin influence the economy of Georgia?**

- A. The planting of cotton became quicker, leading to an increase in farm workers' wages.
- B. Cotton mills in the state became more efficient, helping the South to industrialize.
- C. Cotton could be processed much faster, leading to an increase in the planting of cotton.
- D. Southern plantations moved their cotton swiftly to northern factories, raising the price of cotton.

## Unit 5: The Civil War

In this unit, you will study the Civil War period of history. You will learn about the passage of constitutional amendments and some major battles of the Civil War. You will read about many key events, including the Compromise of 1850, the Dred Scott decision, the Emancipation Proclamation, the Missouri Compromise, Sherman's March to the Sea, and tenant farming.

### KEY TERMS

**13th Amendment:** An amendment to the United States Constitution that ended slavery in the states, except as a criminal penalty. (H6c)

**14th Amendment:** An amendment to the United States Constitution that guaranteed equal rights to racial minorities. The Southern states were required to ratify it before being allowed representation in Congress after the Civil War. (H6c)

**15th Amendment:** An amendment to the United States Constitution that guarantees each individual's right to vote regardless of race. (H6c)

**Andersonville:** A village in southwest Georgia known for its Confederate prisoner-of-war camp. (H6b)

**Antietam:** Site in Maryland where General Robert E. Lee and his Confederate soldiers were defeated by Union forces. (H6b)

**Chickamauga:** The largest battle fought in the state of Georgia. The battle lasted three days and was the second-bloodiest battle of the Civil War. This was the largest Union defeat in the west. (H6b)

**Civil War:** The name of a war fought in the United States between the Northern industrial states and the Southern agricultural states (which had seceded over the issue of slavery and states' rights). It lasted from 1861 to 1865. (H6b)

**Compromise of 1850:** A federal compromise between anti-slavery and pro-slavery forces. It allowed each new state to determine its own status as a free or slave state when entering the Union. (H6a)

**Debate over Secession:** Even within the Southern states, there was much debate over whether leaving the Union was constitutional. Ultimately, Georgia voted to secede. (H6a)

**Dred Scott:** A slave who, on the basis of having lived in free states, sued for his freedom in federal court. The United States Supreme Court ultimately decided that, as property, he had no right to sue. The court also declared parts of the Missouri Compromise unconstitutional because they deprived slave owners of their property. (H6a)

**Election of 1860:** A presidential election that focused on the issue of slavery. Abraham Lincoln, the Republican nominee, opposed slavery, though he promised not to abolish the institution. When he won, however, a number of Southern states voted to secede from the Union. (H6a)

**Emancipation Proclamation:** An executive order issued by President Abraham Lincoln on January 1, 1863, in the midst of the Civil War, declaring an end to slavery in those states that had seceded from the Union. (H6b)

**Freedmen's Bureau:** A government agency established to help former slaves adjust to their new freedom. (H6c)

**Georgia Platform:** A statement issued by the Georgia Convention in response to the Missouri Compromise, affirming state acceptance of the Compromise. (H6a)

**Gettysburg:** The Pennsylvania site of the deadliest battle of the Civil War. (H6b)

**Kansas-Nebraska Act:** An act that repealed the Missouri Compromise of 1820. It permitted new states' white male settlers to decide whether those states would be slave or free. (H6a)

**Ku Klux Klan:** A secretive, violent organization of white supremacists that arose after the Civil War to suppress the rights of African Americans. (H6c)

**Missouri Compromise:** An agreement between anti-slavery and pro-slavery forces that required slave and free states to enter the Union in equal numbers. (H6a)

**Nullification:** A constitutional crisis created when the state of South Carolina passed an ordinance declaring that two federal tariffs would not be observed. (H6a)

**Reconstruction:** A period after the Civil War during which the former Confederacy was required to agree to certain sanctions before being readmitted into the Union with representation in Congress. (H6c)

**Sherman's Atlanta Campaign:** A series of battles fought in Georgia after Union General William T. Sherman invaded the state in an attempt to weaken the South. (H6b)

**Sherman's March to the Sea:** The movement of General William T. Sherman's Union forces from Atlanta, Georgia, to the port of Savannah, resulting in the capture of the port. The march destroyed much of the Confederate army's infrastructure, support, and trade routes. (H6b)

**Slavery:** The ownership and forced labor of one person by another. In the early history of the United States, African American men and women were enslaved in the South. Tensions over anti-slavery forces and pro-slavery forces led to the American Civil War. (H6a)

**States' Rights:** The idea that each state can pass laws without federal involvement. In the decades leading up to the Civil War, most Southerners saw slavery as a states' rights issue. (H6a)

**Alexander Stephens:** The vice president of the Confederate States of America during the Civil War. (H6a)

**Tenant Farming:** A system, prevalent in the South after the Civil War, in which landowners allowed farmers to cultivate their land for a percentage of the profits and/or rent and food. (H6c)

**Henry McNeal Turner:** An African American leader from Georgia who was influential in politics during the Reconstruction Era. (H6c)

**Union Blockade:** A strategy by the Union navy to prevent the South from trading its goods with Europe. (H6b)

---

## Sample Items 7–8

### Item 7

**How did Sherman’s March to the Sea affect the state of Georgia?**

- A. Sherman’s march diverted Union attention from Georgia, allowing the state’s militia to recover.
- B. The March to the Sea destroyed Georgia’s agriculture and roads, devastating the state’s economy.
- C. People in the state were proud that Georgia-born Sherman distinguished himself during the march.
- D. The March to the Sea was the first time the Union army actually entered the state of Georgia.

### Item 8

**What role did Henry McNeal Turner play in Southern Reconstruction?**

- A. He helped found the Ku Klux Klan in Georgia.
- B. He was a principal leader in Southern politics and society.
- C. He was Georgia’s first African American U.S. senator.
- D. He helped create political and religious organizations for freed slaves.



## Unit 6: The New South

In this unit, you will read about important people and events of the New South. The focus will be on the changes that occurred in Georgia between the end of the Civil War and the end of World War I. Many new businesses such as Coca-Cola, Delta Air Lines, and the Georgia-Pacific paper company were developed by entrepreneurs as the South became more industrialized like the North.

### KEY TERMS

**Bourbon Triumvirate:** A name for the three most powerful politicians of the Post-Reconstruction Era: John B. Gordon, Alfred H. Colquitt, and Joseph E. Brown. (H7a)

**John and Lugenia Burns Hope:** Husband-and-wife social reformers who worked to improve the lives of African Americans in Atlanta, Georgia, during the early part of the 20th century. (H7c)

**Coca-Cola:** A producer of popular carbonated beverages based in Atlanta, Georgia. (E3c)

**County Unit System:** A system of voting in which votes were recognized by county rather than by population, resulting in a concentration of political power in rural areas. It was in force from the late 1800s to the early 1960s. (H7a)

**Delta Air Lines:** A large airline company with corporate offices located in Atlanta, Georgia. Its largest hub is located at Hartsfield-Jackson Atlanta International Airport. (E3c)

**W.E.B. Du Bois:** A civil rights activist and author known for his opposition to the Atlanta Compromise, which called for African Americans to accommodate whites in return for basic educational and economic opportunity. (H7c)

**Entrepreneurship:** The process of starting an organization or business. The economies of many countries are supported by small businesses begun by entrepreneurs. (E3c)

**Rebecca Latimer Felton:** A Georgian writer and reformer who became the first woman to serve in the U.S. Senate. (H7a)

**Georgia-Pacific:** One of the largest manufacturers of paper products in the world, located in Atlanta, Georgia. (E3c)

**Henry Grady:** A journalist from Georgia. He was instrumental in the integration of Southern states back into the Union during the Reconstruction Era. He is credited with introducing the term “the New South.” (H7a)

**Alonzo Herndon:** Born into slavery, Alonzo Herndon was emancipated at the end of the Civil War. He went on to own many businesses including barber shops in Atlanta, as well as the Atlanta Life Insurance Company. (H7c)

**Home Depot:** A large U.S. home improvement and construction company headquartered in the Atlanta, Georgia, area. (E3c)

**International Cotton Exposition:** An event held in Atlanta in 1881 to showcase Atlanta as an industrial center and to promote investment in the state. (H7a)

**Leo Frank Case:** A Jewish man from Atlanta, Georgia, who was convicted of murdering a 13-year-old girl. He was believed to be innocent and his conviction led to protests and even riots. Some attributed his conviction to prejudice because he was Jewish. After his murder by a lynch mob, the state of Georgia pardoned him. (H7a)



**Transportation:** Today there are four major systems of transportation in Georgia that work together to move goods throughout the state, the nation, and the world. These include the interstate highway system, Hartsfield-Jackson Atlanta International Airport, Georgia’s deep-water ports, and the state’s railroads. All four systems enable goods to enter and leave the state with relative ease. (G2a)

**Booker T. Washington:** An author and civil rights activist who supported the Atlanta Compromise, which called for African Americans to accommodate whites in return for basic educational and economic opportunity. (H7c)

**Tom Watson:** A writer from Georgia and a leader of the Populist Party of the United States, which sought greater protections for agricultural workers. (H7a)

**World War I:** The first Great War, largely fought in Europe, Africa, and parts of Asia. Georgia contributed more than 100,000 men and women to the war effort. (H7d)

## Sample Items 9–10

### Item 9

**Which of these was an effect of the U.S. Supreme Court ruling in *Plessy v. Ferguson*?**

- A. Many African Americans became small business owners.
- B. Many African American youths were required to work in the fields.
- C. African Americans were restricted from entering many public places.
- D. African American students had access to a college education for the first time.

### Item 10

**Which group of Georgians benefited MOST from the county unit system?**

- A. white farmers
- B. urban residents
- C. Republican candidates
- D. female factory workers

## Unit 7: The 20th Century

In this unit, you will read about events that happened in the 20th century. These include a drought, the Great Depression, and World Wars I and II. You will learn about the invention of aircraft, the destruction of the boll weevil, the lend-lease program, and the Savannah and Brunswick shipyards.

### KEY TERMS

**Agricultural Adjustment Act:** A federal law passed in 1933, ruled unconstitutional, and then modified and passed again in 1938. It set quotas on farm produce in an attempt to keep farmers in business during the Great Depression. (H8d)

**Bell Aircraft:** A corporation that manufactured aircraft and was active during World War II. (H9b)

**Boll Weevil:** A beetle that feeds on flowers and cotton buds. Not native to the United States, it proved disastrous to cotton producers in the American Southeast, including those in Georgia, during the Great Depression. (H8a)

**Civilian Conservation Corps:** A Great Depression-era work relief program that put young American men to work in rural areas. (H8d)

**Drought:** A period of little or no rainfall. A widespread drought in the United States during the 1930s created a dust bowl in parts of the Midwest and West. (H8a)

**The Great Depression:** A sustained period of American economic decline. It lasted from 1929 until the mid-1940s. U.S. entry into World War II led to the end of the Great Depression. (H8b)

**Holocaust:** The mass murder of Jews and other groups by Nazis during World War II. (H9c)

**Lend-Lease:** The Lend-Lease Act in 1941 let the United States aid the Allies in World War II. It was signed by President Franklin Delano Roosevelt, and it allowed the United States to provide aid to Great Britain. (H9a)

**New Deal:** A series of laws enacted by President Franklin Delano Roosevelt during the Great Depression, aimed at rebuilding the American economy. (H8d)

**Pearl Harbor:** A naval base in Hawaii that was attacked by Japan on December 7, 1941, prompting the United States' entry into World War II. (H9a)

**Franklin Delano Roosevelt:** President of the United States from 1933 until his death in 1945. He governed the nation during both the Great Depression and World War II. He first visited Brunswick, Georgia, in 1913 on business for the U.S. Navy. After contracting polio in 1921, he returned to the state, this time to visit Warm Springs, where he hoped the waters would restore him to health. He later purchased a home there and visited it often. (H9d)

**Rural Electrification Act:** An act signed into law by President Roosevelt in 1935 to bring electricity to rural areas throughout the United States. (H8d)

**Richard Russell:** Former governor of Georgia and United States senator. He was known for working to strengthen national defense as well as for opposing civil rights. (H9b)

**Savannah and Brunswick Shipyards:** Ports in Georgia where ships were built. Both were extremely important to the United States during World War II. (H9b)

**Social Security:** A government program established during the Great Depression. It provides an income to elderly people who can no longer work by giving them benefits based on what they paid into the system while working. (H8d)

**Eugene Talmadge:** A three-term governor of Georgia who served in the 1930s and 1940s. (H8c)

**Carl Vinson:** A Georgia native who served in the U.S. House of Representatives. He was the first to hold congressional office for a period of fifty years. He is known as “The Father of the Two-Ocean Navy.” (H9b)

**World War II:** The largest war in history. Conflict extended into Europe, Africa, Asia, and both the Pacific and Atlantic Oceans. (H9a)

## Sample Items 11–12

### Item 11

**Which group of people was MOST affected by the boll weevil in the years between World War I and World War II?**

- A. cotton farmers
- B. factory workers
- C. railroad workers
- D. government officials

### Item 12

**How was Georgia significant in the life of President Franklin Delano Roosevelt?**

- A. Georgia politicians led the anti-Roosevelt opposition in Congress during the 1930s.
- B. President Roosevelt traveled to Warm Springs frequently to recover from complications of polio.
- C. Georgia’s Electoral College votes gave Roosevelt enough votes to win the presidential election in 1932.
- D. President Roosevelt tested his New Deal programs in the state before spreading them across the country.

## Unit 8: Post-WWII Georgia

In this unit, you will learn about Georgia after World War II. You will study the rise of agriculture, the growth of businesses, and the importance of transportation. You will learn about the capital, Atlanta, and you will also read about the important sports teams in the state.

### KEY TERMS

**Agriculture:** The science of farming. It is an important part of Georgia's economy. During the Civil War, cotton was the state's leading product and was shipped to ports around the world. Today, the state is the world's leading producer of pecans. It continues to produce cotton and is a major world supplier of peaches, peanuts, rye, and tobacco, as well as poultry and eggs. (H10a)

**Ivan Allen, Jr.:** The two-term mayor of Atlanta during the civil rights era of the 1960s. He opposed segregation and helped revitalize the city's economy. (H10b)

**Ellis Arnall:** The governor of Georgia from 1943 to 1947. He repealed the poll tax and ratified a new state constitution. At the time, he was the youngest governor serving in the United States. (H10c)

**Atlanta:** The capital of and largest city in Georgia, founded in 1837. It is the ninth-largest metropolitan area in the United States, and its economy is the eighth largest in the nation. That economy is largely supported by corporate giants that call the area home: Coca-Cola, Home Depot, CNN, TBS, Cox Enterprises, The Weather Channel, Delta Air Lines, and Georgia-Pacific, among many others. (H10b)

**William B. Hartsfield:** The two-time mayor of Atlanta who helped develop the city's airport into the major transportation hub it has become today. (H10b)

**Sports:** Professional athletics programs thrive in Georgia. The state is home to the Atlanta Braves (baseball), Atlanta Hawks (basketball), Atlanta Falcons (football), Atlanta Silverbacks (hockey), and a number of other teams and organizations. It also hosts golf's Masters Tournament and a number of motorsports races. (H10b)

**KEY IDEA****Transportation in Georgia**

Georgia is a major transportation hub. The state capital, Atlanta, is one of the nation's leading railroad centers. The city also has one of the nation's largest airports, Hartsfield-Jackson Atlanta International, which has been considered the busiest passenger airport in the world since 1998.

Georgia also has two of the nation's busiest deep-water ports at Savannah and Brunswick. Between the years 2000 and 2005, Savannah was the nation's fastest-growing seaport. The port at Brunswick is equally as important and was once known as "The Shrimp Capital of the World."

The state is also home to a number of important highways that connect Atlanta to other parts of the nation. Among them is I-75, which connects Michigan to Florida while going through a number of important cities.

**Sample Items 13–14****Item 13**

**How did changes in Georgia's agriculture during the second half of the 20th century affect the distribution of population in the state?**

- A. New agricultural practices were developed, leading more people to move to rural areas.
- B. Many small farms were consolidated into larger farms, causing thousands of farmers to move to the cities.
- C. Government assistance in farming helped local growers, allowing them to continue living in rural areas.
- D. New cotton mills were built as a result of the increase in cotton production, forcing people to move near the mills.

**Item 14**

**How did the development of Atlanta after World War II affect the growth of Georgia?**

- A. Atlanta's growth turned the city into the economic center of the state.
- B. Atlanta's growth marked the end of the state being a leader in agriculture.
- C. As Atlanta grew, the rest of the state saw a decrease in the economy and an increase in poverty.
- D. As Atlanta grew, the rest of the state showed a decrease in population and an increase in the average age of the people.

## Unit 9: Civil Rights

In this unit, you will learn about the Civil Rights Movement and some of its leaders. You will learn about a landmark court case and the March on Washington. You will read about Maynard Jackson, Martin Luther King, Jr., Lester Maddox, and Andrew Young.

### KEY TERMS

**Albany Movement:** A coalition of the Student Nonviolent Coordinating Committee, the National Association for the Advancement of Colored People, and activists from Albany, Georgia, that worked to end segregation. (H11b)

**Brown v. Board of Education:** A landmark 1954 case in which the U.S. Supreme Court ruled “separate but equal” and race-based segregation of public school students to be unconstitutional. (H11a)

**Civil Rights Movement:** A national movement undertaken by African Americans and their supporters in the 1950s and 1960s to end segregation and ensure equal rights for minorities. (H11a)

**Governor’s Race of 1946:** In 1946, Georgia’s governor-elect, Eugene Talmadge, died before taking office. The General Assembly voted his son, Henry Talmadge, into office. The newly elected lieutenant governor, Melvin Thompson, however, insisted that he was the new governor. The Georgia Supreme Court ultimately ruled that Thompson was the rightful acting governor until a special election could be held to replace the elder Talmadge. (H11a)

**Hamilton Holmes:** One of the first two African American students to enroll at the historically segregated University of Georgia. (H11b)

**Charlayne Hunter:** One of the first two African American students to enroll at the historically segregated University of Georgia. (H11b)

**Maynard Jackson:** Atlanta’s first African American mayor. He served three terms. (H11b)

**Martin Luther King, Jr.:** African American civil rights leader of the 1950s and 1960s who opposed segregation. He believed in nonviolence and organized the March on Washington. He received a Nobel Peace Prize in 1964. He was assassinated on April 4, 1968. Martin Luther King Day is a federal holiday honoring his date of birth. (H11a)

**Lester Maddox:** A segregationist who rose to fame after refusing to serve African Americans in his restaurant. He later became governor of Georgia and softened his views on civil rights. His administration saw improved conditions for minorities in the state, and he later served as lieutenant governor under Jimmy Carter. (H11b)

**March on Washington:** On August 28, 1963, approximately 250,000 people, mostly African American, gathered before the Lincoln Memorial in Washington, D.C., to demand equal protection under the law for African Americans. It was at this event that Martin Luther King, Jr., gave his famous “I Have a Dream” speech. (H11b)

**Benjamin Mays:** An African American minister, educator, and activist who was president of Morehouse College in Atlanta, Georgia, from 1940 until 1967. He was a mentor to Martin Luther King, Jr. (H11a)

**Sibley Commission:** A commission charged by Governor Ernest Vandiver, Jr., with studying segregation in the state of Georgia. The commission laid the groundwork for the end of state resistance to forced integration. (H11b)

**Student Nonviolent Coordinating Committee:** An organization formed in 1960 to further the cause of equal rights for minorities. It is most famous for organizing sit-ins at universities and freedom rides into the South. (H11b)

**Henry Talmadge:** Governor of Georgia from 1948 to 1955, he was at the center of the “Three Governors Controversy” of 1946. (H11a)

**White Primary:** Primary elections in which only whites were allowed to vote. In 1944, the United States Supreme Court ruled them unconstitutional, and most Southern states ended the practice. (H11a)

**Andrew Young:** An African American minister and activist from Georgia who served as representative for Georgia’s fifth district, mayor of Atlanta, president of the National Council of Churches USA, and United States Ambassador to the United Nations. (H11c)

## Sample Item 15

### Item 15

**Who was the first African American mayor of Atlanta?**

- A. Benjamin Mays
- B. Maynard Jackson
- C. Herman Talmadge
- D. Martin Luther King, Jr.

## Unit 10: Modern Georgia

In this unit, you will learn about modern-day Georgia. You will read about governmental and political ideas such as reapportionment. You will learn about the Olympic Games of 1996, and you will study President Jimmy Carter and his many contributions to the state and the nation.

### KEY TERMS

**Olympic Games of 1996:** Held in Atlanta, Georgia, the Summer Games brought international attention to the state. The Games are estimated to have brought over 5 billion U.S. dollars into the city of Atlanta. The economic boost resulted in improved housing, sidewalks, and roads and in the construction of new sports venues in the city. (H12d)

**Reapportionment:** The act of examining an area's population distribution and making changes to the way voting districts are drawn. (H12a)

**Two-Party System:** A political system in which two major parties dominate government. In the United States and in the state of Georgia, those parties are the Republican Party and the Democratic Party. (H12c)

### KEY IDEA

#### Jimmy Carter

Georgia native Jimmy Carter began his career in the U.S. Navy. After leaving the military, Carter, by then married and with three children, took over the family peanut farm.

In 1962 Carter jumped into local politics. He ran for the Senate, losing at first. He challenged the results, and when they were revealed to have been illegally tampered with by a local sheriff, another vote was held and Carter won.

After running for governor and losing, Carter returned to farming. Four years later, he again ran for governor, but this time he won. In 1976, he threw his hat into the presidential ring. A relative unknown at first, he became the frontrunner by mid-March of that year. In November, he won the election against incumbent President Gerald Ford with 50.1% of the vote. His presidency proved controversial, but he did oversee the creation of over ten million jobs.

Despite losing reelection to Ronald Reagan in a landslide in 1980, Carter has kept busy in his later years. In addition to teaching, lecturing, and writing multiple books, he established the Carter Center in Atlanta in 1982. The purpose of the Center is to fight human rights abuses, human trafficking, and disease worldwide. In 2002, he was awarded the Nobel Peace Prize. He is one of only four presidents to win the prize, and the only one to do so for work not related to his presidency. (H12b)



## Sample Items 16–17

### Item 16

**How has Jimmy Carter contributed to the area of human rights?**

- A. He worked for human rights as a constitutional lawyer in Georgia.
- B. He drafted human rights legislation when he was Georgia’s governor.
- C. He placed human rights at the center of his foreign policy as president.
- D. He rescued victims of human rights abuses when he was a naval officer.

### Item 17

**How do immigrant groups affect the Georgia economy?**

- A. They reintroduce bartering.
- B. They perform essential jobs and buy goods.
- C. They cause state government revenues to decline.
- D. They revive public and private industry labor unions.

## Unit 11: State and Local Government

In this unit, you will focus on the state and local government systems. You will learn about laws and the separation of powers. You will study the justice system and the courts and learn something about criminal law and the state's constitution.

### KEY TERMS

**Council-manager:** A form of local government in which leadership of a town or area is divided between a group of council members and a manager. (CG5b)

**Executive branch:** The branch of government tasked with enforcing the law. It is headed by the governor and includes the aspects of government that cover public safety, education, transportation, human resources, and economic development. It also includes state agencies and law enforcement. (CG3a, b)

**General Assembly:** Georgia's legislative branch of government is bicameral, meaning it has two parts: a House and a Senate. Each of the General Assembly's 236 members is elected directly by the people of his or her district and serves a two-year term. Each member must be a resident of the district that he or she represents, a resident of the state for at least two years, and at least 25 years of age. The General Assembly includes committees that study and examine issues pertaining to bills before they are presented to the entire Assembly. The ultimate job of the Assembly is to craft the state's laws. (CG2a, b, c)

**Georgia's State Constitution:** Divides government into three branches: the legislature, which is bicameral; the judiciary, which is headed by the state supreme court; and the executive, which is presided over by the governor. Checks and balances among the branches prevent any one branch from becoming too powerful. (CG1a, b)

**Governor:** The leader of the executive branch of state government. In Georgia, the governor is tasked with signing bills into law or vetoing them; appointing leaders to various state agencies; and overseeing the state's affairs in general. Candidates for governor must be at least 30 years old when taking office, a U.S. citizen for 15 years, and a resident of the state for at least 6 years. Each term is limited to four years, and individuals are limited to two consecutive terms. (CG3a)

**Lieutenant governor:** As both the leader of the Senate and the second-in-command of the state, the lieutenant governor is a member of both the legislative and executive branches. He or she is elected by popular vote and reports to the governor. If the governor dies in office, the lieutenant governor assumes the role of governor for the remainder of the term. As president of the Senate, he or she guides bills through the General Assembly but does not vote on them. Each term is four years in length, and the candidate must meet the same requirements as the candidate for governor. (CG3a)

**Local government:** In Georgia is divided between counties and cities. The counties are overseen by either a single commissioner or a committee of multiple commissioners, who are elected to terms lasting anywhere from two to six years. They hold both legislative and executive power. Cities are mostly governed by a mayor and a city council. (CG5a, d)

**Special purpose governments:** Districts usually created by cities or counties as "city business improvement" districts. (CG5c)

**State revenue:** The money gathered by the state to pay its bills. This money can be collected through a sales tax, or money charged to consumers when they purchase a product; a federal grant, or money given to the state by the federal government for a specific purpose; personal income taxes, or money collected from an individual from the money he or she makes in a year; and property taxes, or the money that is collected from individuals who own property. The money that is collected is then spent on such things as police officers, firefighters, judges, statewide officeholders, programs designed to benefit members of the state, and so on. (E4a, b, c)

**Strong mayor-council:** A system in which the mayor holds the greatest degree of a city or town's authority, though the budget must be approved by the city council. (CG5b)

**Weak mayor-council:** A system in which the city council holds the greatest degree of a city or town's authority. (CG5b)

## Sample Items 18–19

### Item 18

**How long is the term of office for Georgia's governor?**

- A. 2 years
- B. 4 years
- C. 5 years
- D. 7 years

### Item 19

**The Environmental Protection Division of the Georgia Department of Natural Resources implements water standards for the state. The local water districts in the state are responsible for ensuring that the quality of the water in their districts meets those standards. What is this an example of?**

- A. independence of local governments to determine water policy
- B. state and local agencies working together to administer water programs
- C. conflicts of interest between state and local governments over water policy
- D. efforts by the state government to control the distribution of water in local communities

## Unit 12: Adult and Juvenile Justice Systems

In this unit, you will learn about the adult and juvenile justice systems. You will read about civil laws and the court system. You will study about criminal law.

### KEY TERMS

**Adult Justice System:** A system of law enforcement tasked with apprehending, prosecuting, defending, and sentencing adults convicted of criminal behavior. (CG4c)

**Civil Law:** The system of law that deals with private interactions between individuals. (CG4b)

**Court System:** Georgia's judicial branch is divided into trial and appellate courts overseen by a supreme court. Trial courts are concerned with cases that are tried; appellate courts hear appeals from those trial courts. Judges are chosen by voters in nonpartisan elections. Midterm vacancies are filled by the governor. One role filled by the judicial branch in Georgia is the interpretation of laws. Courts must sometimes decide whether a law meets the standards set by the state constitution. (CG4a, e)

**Criminal Law:** The area of law concerned with judging and sentencing criminal behavior. (CG4b)

### Sample Items 20–21

#### Item 20

**Which right do all juveniles have when taken into custody?**

- A. the right to a fair trial
- B. the right to be judged as an adult
- C. the right to have a jury of juvenile peers
- D. the right to a lesser sentence than an adult

#### Item 21

**Which behavior might cause a juvenile to be treated as an adult during the criminal process?**

- A. committing armed robbery
- B. painting graffiti on a building
- C. getting into a fight with someone
- D. driving faster than the speed limit

## Unit 13: Personal Finance

In this unit, you will learn about personal finance. You will read about income, credit, spending, and saving.

### KEY TERMS

**Credit:** The ability of a consumer to obtain a good or service with the payment to come in the future. (E5)

**Income:** The money a person earns through work or investments. (E5)

**Investment:** The placing of money in a share, property, scheme, or commercial venture with the expectation that it will earn more money in the future, though the possibility always exists that it will be lost. (E5)

**Savings:** Money a person or institution sets aside. Money saved in a bank earns interest over time. (E5)

**Spending:** Money a person expends in order to obtain something. (E5)

### Sample Items 22–23

#### Item 22

**Which of these is an example of income?**

- A. Ali buys a new pair of brand-name sneakers.
- B. Sam takes out a loan to pay for his tuition for college.
- C. Maria puts money into a savings account at her local bank.
- D. Timothy earns an hourly wage working at a fast-food restaurant.

#### Item 23

**Which of these is an example of someone using credit?**

- A. Candace purchases a new smartphone with cash.
- B. Malik borrows money from the bank to buy a new car.
- C. Ralph puts money into a fund for college each pay period.
- D. Cheryl receives twenty-five dollars each time she mows the lawn.

## SOCIAL STUDIES ADDITIONAL SAMPLE ITEM KEYS

Item	Standard/ Element	DOK Level	Correct Answer	Explanation
1	SS8H1a	1	C	The correct answer is choice (C) Woodland. Choices (A), (B), and (D) are not correct because the Paleo and Archaic cultures were mostly hunter-gatherer cultures and the Mississippian culture was based on agriculture and occurred after the shift from hunting and gathering.
2	SS8H1a	2	A	The correct answer is choice (A) Mississippian society was organized into chiefdoms. Choices (B), (C), and (D) are all characteristics that the Woodland culture and the Mississippian culture shared.
3	SS8H1c	3	C	The correct answer is choice (C) The Spanish, French, and British all had economic interests in the Southeast. The conclusions in choices (A), (B), and (D) are not supported by the chart.
4	SS8H1b	2	C	The correct answer is choice (C) European exploration and colonization. Choices (A), (B), and (D) are incorrect because, although some of the conditions listed in the box were caused by these events, only European exploration and colonization caused all of them.
5	SS8H3b	2	B	The correct answer is choice (B) to end the British military occupation of the city. Choice (A) is incorrect because there was no blockade of British ships. Choice (C) is incorrect because, although Savannah, like most American cities, had both Loyalists and Patriots, the main objective of the siege was to end British occupation. Choice (D) is incorrect because this was not a goal of the Continental Army.
6	SS8H5c	2	C	The correct answer is choice (C) Cotton could be processed much faster, leading to an increase in the planting of cotton. Choices (A), (B), and (D) are incorrect because they are unrelated to the cleaning of cotton for the mills.
7	SS8H6b	2	B	The correct answer is choice (B) The March to the Sea destroyed Georgia's agriculture and roads, devastating the state's economy. Choices (A) and (C) are incorrect because Sherman was a Union general, not a Confederate general. Choice (D) is incorrect because the March to the Sea was not the first time that the Union army entered Georgia.

Item	Standard/ Element	DOK Level	Correct Answer	Explanation
8	SS8H6c	2	D	The correct answer is choice (D) He helped create political and religious organizations for freed slaves. Choice (A) is incorrect because, as an African American, Turner would not belong to this group. Choice (B) is incorrect because, though he was involved in politics, he was not a principal leader in politics and society. Choice (C) is incorrect because, although Turner was elected to office, he was not elected to the U.S. Senate.
9	SS8H7b	2	C	The correct answer is choice (C) African Americans were restricted from entering many public places. Choice (A) is incorrect because <i>Plessy v. Ferguson</i> enforced segregation and did not promote African American business owners. Choice (B) is incorrect because African Americans were not necessarily forced to work in the fields. Choice (D) is incorrect because African American students attended college throughout the post–Civil War era.
10	SS8H7a	2	A	The correct answer is choice (A) white farmers. Choice (B) is incorrect because urban voters were disadvantaged by the county unit system. Choice (C) is incorrect because Georgia had a Democratic majority during this time period. Choice (D) is incorrect because most factory workers were in urban areas, which were disadvantaged by the county unit system.
11	SS8H8a	2	A	The correct answer is choice (A) cotton farmers. Choices (B), (C), and (D) are incorrect because an insect that attacked cotton plants would not affect these populations as much as it would affect cotton farmers.
12	SS8H9d	2	B	The correct answer is choice (B) President Roosevelt traveled to Warm Springs frequently to recover from complications of polio. Choice (A) is incorrect because most Georgians supported President Roosevelt. Choice (C) is incorrect because, although Georgia’s Electoral College votes were important, they were not any more essential than those of other states. Choice (D) is incorrect because, although President Roosevelt conceived of some New Deal programs while visiting Georgia, the state was not a testing ground for its programs.

Item	Standard/ Element	DOK Level	Correct Answer	Explanation
13	SS8H10a	2	B	The correct answer is choice (B) Many small farms were consolidated into larger farms, causing thousands of farmers to move to the cities. Choice (A) is incorrect as changes in agricultural practices led people to live in urban areas rather than in rural areas. Choice (C) is incorrect because government assistance did not lead people to continue living in rural areas. Choice (D) is incorrect because the growth of cotton decreased during this period.
14	SS8H10b	3	A	The correct answer is choice (A) Atlanta's growth turned the city into the economic center of the state. Choice (B) is incorrect because Georgia's agriculture remains strong. Choice (C) is incorrect because the economy in other areas of the state continued to increase. Choice (D) is incorrect because the growth of Atlanta did not cause a population decrease in the state.
15	SS8H11b	1	B	The correct answer is choice (B) Maynard Jackson. Choice (A) is incorrect because Mays was a well-known African American leader in the 1940s, 1950s, and 1960s. Choice (C) is incorrect because Talmadge was a governor of Georgia in the late 1940s and early 1950s who supported segregation. Choice (D) is incorrect because King was a well-known civil rights leader, but he did not become mayor.
16	SS8H12b	2	C	The correct answer is choice (C) He placed human rights at the center of his foreign policy as president. Choice (A) is incorrect because he never worked as a constitutional lawyer. Choice (B) is incorrect because he never drafted human rights legislation as governor. Choice (D) is incorrect because, although he served in the United States Navy, he did not rescue victims of human rights abuses.
17	SS8H12e	2	B	The correct answer is choice (B) They perform essential jobs and buy goods. Choices (A) and (D) are incorrect. Immigrants do not typically engage in these activities. Choice (C) is incorrect. State revenues increase through increased state economic activity.
18	SS8CG3a	1	B	The correct answer is choice (B) 4 years. Choices (A), (C), and (D) are not true.



Item	Standard/ Element	DOK Level	Correct Answer	Explanation
19	SS8CG5d	2	B	The correct answer is choice (B) state and local agencies working together to administer water programs. They represent a shared responsibility between state and local governments. Choices (A), (C), and (D) do not reflect the shared responsibility.
20	SS8CG6b	1	A	The correct answer is choice (A) the right to a fair trial. Choices (B) and (D) are incorrect because they are only true in some circumstances. Choice (C) is incorrect because juvenile cases are judged in the juvenile court and not by a jury of juveniles.
21	SS8CG6d	2	A	The correct answer is choice (A) committing armed robbery. Choices (B), (C), and (D) are incorrect because the crimes are not considered severe enough to be treated as adult crimes.
22	SS8E5	2	D	The correct answer is choice (D) Timothy earns an hourly wage working at a fast-food restaurant. Choice (A) is an example of spending. Choice (B) is an example of credit. Choice (C) is an example of saving.
23	SS8E5	2	B	The correct answer is choice (B) Malik borrows money from the bank to buy a new car. Choice (A) is an example of spending. Choice (C) is an example of saving. Choice (D) is an example of income.

## ACTIVITY

The following activity develops skills in Unit 5: The Civil War.

Standard: SS8H6c

### Impact of Reconstruction

- I. Select one of the topics listed below:
  - a. Freed slaves
  - b. Plantation owners
  - c. Northern carpetbaggers
  - d. White sharecroppers
  - e. Southern scalawags
  - f. Radical Republicans in Washington, D.C.
  
- II. Research the topic and note the following:
  - a. The status of this group before the Civil War
  - b. How the group was affected by the events of the Civil War
  - c. How Reconstruction has changed the group's life (in positive and/or negative ways)
  - d. How the group might feel about the changes Reconstruction brought to Georgia
  
- III. Imagine that you lived in 1876. Based on your research, write a letter to your local newspaper giving your opinion on whether Reconstruction should be ended in the South. Be sure to cite evidence (based on your research) on how Reconstruction has affected Georgia.

This activity could be adapted to different eras in Georgia history. Possibilities include:

- a. Georgia Exploration and British Colonization (Native Americans, mission Native Americans, Spanish, English, etc.)
- b. Revolution (Native Americans, enslaved Africans, Loyalists, Patriots, British soldiers)
- c. Civil War (enslaved Africans, soldiers' wives and sisters, soldiers, generals, plantation owners)
- d. The New South (rural Georgians, urban Georgians, factory workers, sharecroppers, etc.)

**ACTIVITY**

The following activity develops skills in Unit 11: State and Local Government.

**Standard:** SS8CG1

**Rights of Citizens**

Identify various rights of the citizens of Georgia.

Read the Georgia Constitution, Article I, Section 1. Identify 7–8 rights that may particularly apply to you.

Remember that citizens have rights and responsibilities.

Write down each right in a chart similar to the one below. Then discuss with a family member or friend what these rights mean, and note the meaning in the right column.

Right	What it means

1. Choose a particular right from the 7–8 rights selected.
2. Write a paragraph describing the significance of that right in your life or the lives of people you know. For example, the right to the freedom of conscience might mean that Fatima goes to the mosque, Daniel goes to the synagogue, Maria goes to church, and Parker does not attend any religious services.
3. Share what you wrote with a family member or friend and discuss whether there are other examples of the significance of that right.

## APPENDIX A: LANGUAGE PROGRESSIVE SKILLS, BY GRADE

The following skills, marked with an asterisk (\*) in Language standards 1–3, are particularly likely to require continued attention in higher grades as they are applied to increasingly sophisticated writing and speaking.

Standard	Grade(s)							
	3	4	5	6	7	8	9–10	11–12
<b>L.3.1f.</b> Ensure subject-verb and pronoun-antecedent agreement.								
<b>L.3.3a.</b> Choose words and phrases for effect.								
<b>L.4.1f.</b> Produce complete sentences, recognizing and correcting inappropriate fragments and run-ons.								
<b>L.4.1g.</b> Correctly use frequently confused words (e.g., <i>to/too/two; there/their</i> ).								
<b>L.4.3a.</b> Choose words and phrases to convey ideas precisely.*								
<b>L.4.3b.</b> Choose punctuation for effect.								
<b>L.5.1d.</b> Recognize and correct inappropriate shifts in verb tense.								
<b>L.5.2a.</b> Use punctuation to separate items in a series.†								
<b>L.6.1c.</b> Recognize and correct inappropriate shifts in pronoun number and person.								
<b>L.6.1d.</b> Recognize and correct vague pronouns (i.e., ones with unclear or ambiguous antecedents).								
<b>L.6.1e.</b> Recognize variations from standard English in their own and others' writing and speaking, and identify and use strategies to improve expression in conventional language.								
<b>L.6.2a.</b> Use punctuation (commas, parentheses, dashes) to set off nonrestrictive/parenthetical elements.								
<b>L.6.3a.</b> Vary sentence patterns for meaning, reader/listener interest, and style.‡								
<b>L.6.3b.</b> Maintain consistency in style and tone.								
<b>L.7.1c.</b> Places phrases and clauses within a sentence, recognizing and correcting misplaced and dangling modifiers.								
<b>L.7.3a.</b> Choose language that expresses ideas precisely and concisely, recognizing and eliminating wordiness and redundancy.								
<b>L.8.1d.</b> Recognize and correct inappropriate shifts in verb voice and mood.								
<b>L.9-10.1a.</b> Use parallel structure.								

\* Subsumed by L.7.3a

† Subsumed by L.9-10.1a

‡ Subsumed by L.11-12.3a

## APPENDIX B: CONDITION CODES

The student response is flawed for various reasons and will receive a condition code. Students who receive a condition code have a score of zero (0).

- For the extended writing tasks, both traits receive a score of 0. For Trait 1: Ideas 0 out of 4 possible points and for Trait 2: Language Usage 0 out of 3 points. (Or 0 points out of a possible 7 points.)
- For the narrative item, the score is 0 out of a possible 4 points

CODE	Performance Scoring: Code Description	Full Description
A	Blank	<ul style="list-style-type: none"> <li>• Blank</li> <li>• Student's response did not contain words.</li> <li>• In some instances, student may have drawn pictures</li> </ul>
B	Copied	<ul style="list-style-type: none"> <li>• Student's response is not his/her own work.</li> <li>• Student does not clearly attribute words to the text(s).</li> <li>• Student copies from the text(s) that serve as writing stimulus.</li> </ul>
C	Too Limited to Score/Illegible/Incomprehensible	<ul style="list-style-type: none"> <li>• Student's response is not long enough to evaluate his/her ability to write to genre or his/her command of language conventions.</li> <li>• Response is not able to be deciphered.</li> <li>• An illegible response does not contain enough recognizable words to provide a score.</li> <li>• An incomprehensible paper contains few recognizable English words or it may contain recognizable English words arranged in such a way that no meaning is conveyed.</li> </ul>
D	Non-English/ Foreign Language	<ul style="list-style-type: none"> <li>• Written in some language other than English.</li> <li>• The writing items/tasks on the test require the student to write in English.</li> </ul>
E	Off Topic/Off Task/ Offensive	<ul style="list-style-type: none"> <li>• Student may have written something that is totally off topic (e.g., major portion of response is unrelated to the assigned task).</li> <li>• Student response did not follow the directions of the assigned task (i.e., off task).</li> <li>• Student uses inappropriate or offensive language/picture.</li> </ul>

Study/Resource Guide  
for Students and Parents  
Grade 8  
End-of-Grade

